

Take your time

In all probability, things are the same for you as they are for many of us in our industry. **The demands on our business are constantly growing**, the level of complexity rises by the day and more and more challenges seem to lie in wait for us with ever-increasing frequency. As a result, when it comes to creating **tailor-made solutions** for new construction and renovation **based on the specific needs of our customers**, time is often in short supply.

But in this day and age, that is where the real opportunities lie. By offering new concepts for building automation systems, energy efficiency and the use of renewable energies, we are able to make the **day-to-day tasks of our customers safer and more comfortable** while also ensuring our business continues to develop dynamically. Hager employs more than 800 developers, who are constantly working on these solutions all around the world. In other words: we take our time to make **truly ground-breaking innovations** and intelligent technologies which are **just as quick to install as they are easy to use**. And of course, we also continue to provide you with all of the reliable products and safe solutions we have been long known for here at Hager.

We have been doing this **for around 60 years**. And we are only as successful as we are at what we do because of the trust you continue to place in us. I would like to take this opportunity to **express our warmest thanks** to you for this continued trust in us – and to recommend that you take a good look at our new catalogue, which serves as a **practical tool for electrical engineering**.

Please do take the time to consult the catalogue every now and again. It provides a **handy overview** of all of the solutions we use not only to save you a lot of time and effort, but also to **constantly tap into new sales potential**. And just in case you have any questions: the details of the contact partner for your region can be found on back cover. They will be happy to assist you at any time. **Hager is always on your side** – as it has been for six decades and will continue to be in the electrifying future that lies ahead of us.

We at Hager look forward to **shaping this time with you**.

Best wishes,

Daniel Hager
CEO of Hager Group

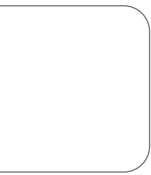

The specialist for electrical installations

Since 1955 Hager is the specialist for electrical installations in residential and commercial sectors, as a standard you can receive everything from one source: systems and solutions with high quality, reliability and ease of installation.

New ideas for the customers' benefit

Together with customers from industry and the electrical trade, Hager Group is working on future topics such as electro-mobility, Ambient Assisted Living, where building automation facilitates the everyday life of the elderly and individuals who require care, and on the networking

of energy-efficient housing, which will provide greater comfort while requiring less energy consumption. The link between many of these technologies will be the distribution board, the product with which the company achieved its growth.

A leading group

The Hager brand represents the core business of Hager Group.

The company was founded in 1955 by Hermann Hager and Dr. Oswald Hager together with their father Peter and today remains an independent business, owned and run by members of the Hager family, with its head office in Blieskastel, Germany. The organisation of the company as a European Company (Societas Europaea, SE) underlines both its cultural diversity and its European roots. Hager Group is, though, a worldwide business venture: 11,400 employees and generates a turnover of around 1.6 billion euros (2013).

Highly innovative achievements provide a market edge with more than 830 employees working in R&D. With more than 5% of turnover reinvested in R&D, Hager Group filed a total of 1513 patents to date.

Components and solutions are produced in 22 production sites around the globe and customers in more than 80 countries all over the world trust in them.

Cat.ref.	Page No.	Cat.ref.	Page No.	Cat.ref.	Page No.	Cat.ref.	Page No.	Cat.ref.	Page No.
AD		EE825	70	ERC218	42	ESL226	43	JAE	
AD119	20	EE826	70	ERC225	45	ESL227	43	JAE316S-IP55	32
AD120	20	EE827	70	ERC226	45	ESL240	43	JAE320	32
AD122	20	EE828	70	ERC240	45	ESL241	43	JAE325	32
AD123	20	EE830	70	ERC263	45	ESL263	43	JAE325S-IP55	32
AD124	20	EE831	70	ERC316	42	ESL264	43	JAE416S-IP55	32
AD125	20	EE840	70	ERC325	45	ESL425	44	JAE420	32
AD126	20	EE841	70	ERC416	42	ESL426	44	JAE425	32
AD127	20	EE855	70	ERC418	42	ESL427	44	JAE425S-IP55	32
AD128	20	EE856	70	ERC425	45	ESL428	44		
AD610B	20	EE860	70	ERC426	45	ESL440	44	JAG	
AD616B	20	EE861	70	ERC427	45	ESL463	44	JAG331	32
AD620B	20	EE870	70	ERC428	45			JAG331S-IP55	32
AD625B	20	EE871	70			ESM		JAG340	32
AD632B	20	EE883	71	ERD		ESM225	43	JAG340S-IP55	32
AD640B	20			ERD216	42	ESM227	43	JAG431	32
		EG		ERD217	42	ESM440	44	JAG431S-IP55	32
CD		EG010	58	ERD218	42			JAG440	32
CD216B	19	EG071	58	ERD225	45	HLE		JAG440S-IP55	32
CD225B	19	EG103B	58	ERD240	45	HLE180S	14		
CD240B	19	EG103V	58	ERD263	45	HLE190S	14	JAH	
CD263B	19	EG110	58	ERD418	42	HLE199S	14	JAH363	32
CD280B	19	EG170	58	ERD418S	42	HLE280S	14	JAH363S-IP55	32
CD284B	19	EG203B	58	ERD425	45	HLE290S	14	JAH380	32
CD425B	19	EG210	58			HLE299S	14	JAH390	32
CD440B	19	EG270	58	ERL		HLE380S	14	JAH392	32
CD463B	19			ERL216	42	HLE390S	14	JAH463	32
CD482B	19	EH		ERL217	42	HLE399S	14	JAH463S-IP55	32
CD485B	19	EH010	54	ERL218	42	HLE480S	14	JAH480	32
		EH011	54	ERL225	45	HLE490S	14	JAH490	32
CE		EH071	54	ERL240	45	HLE499S	14	JAH492	32
CE225B	19	EH110	54	ERL263	45			JG	
CE240B	19	EH110A	54	ERL418	42	HLF		JG220IN	34
CE263B	19	EH111	54	ERL418S	42	HLF180S	14	JG220U	34
CE280B	19	EH111A	54	ERL425	45	HLF190S	14	JG232IN	34
CE284B	19	EH171A	54			HLF199S	14	JG232U	34
CE425B	19	EH191	54	ESC		HLF280S	14	JG240IN	34
CE440B	19	EH209	54	ESC001	46	HLF290S	14	JG240U	34
CE463B	19	EH210	54	ESC002	46	HLF299S	14	JG263IN	34
CE480B	19	EH211	54	ESC003	46	HLF380S	14	JG263U	34
CE484B	19	EH271	54	ESC080	46	HLF390S	14	JG320IN	34
		EH710	56	ESC125	43	HLF399S	14	JG320U	34
CF		EH710A	56	ESC126	43	HLF480S	14	JG325S	34
CF225B	19	EH711	56	ESC225	43	HLF490S	14	JG332IN	34
CF240B	19	EH770	56	ESC225	43	HLF499S	14	JG332U	34
CF263B	19	EH771	56	ESC226	43			JG363S	34
CF280B	19	EH900	56	ESC227	43	HZ		JG380S	34
CF284B	19	EH901	54	ESC240	43	HZ021	32	JG440IN	34
CF425B	19	EH902	54	ESC241	43	HZ022	32	JG440U	34
CF440B	19			ESC263	43	HZ023	32	JG463IN	34
CF463B	19	EN		ESC264	43	HZ025	32	JG463U	34
CF480B	19	EN145	42	ESC325	43	HZ036	32		
CF484B	19	EN146	42	ESC340	43	HZ037	32	JZA	
		EPN		ESC363	43	HZ046	32	JZA700	32
CG		EPN050	39	ESC425	44	HZ047	32	JZA701	32
CG225B	19	EPN051	39	ESC426	44			JZA702	32
CG240B	19	EPN052	39	ESC427	44	HZC			
CG263B	19	EPN053	39	ESC428	44	HZC201	32	LS	
CG280B	19	EPN053	39	ESC440	44	HZC202	32	LS501	23
CG284B	19	EPN501	38	ESC441	44	HZC203	32	LS502	23
CG425B	19	EPN503	38	ESC442	44	HZC204	32	LS503	23
CG440B	19	EPN510	38	ESC443	44	HZC205	32	LS504	23
CG463B	19	EPN511	38	ESC463	44	HZC206	32	LS512	23
CG480B	19	EPN512	38	ESC464	44			LZ	
CG484B	19	EPN513	38	ESC465	44	JAB		LZ060	46
		EPN515	38	ESC466	44	JAB302	32		
CZ		EPN516	38			JAB303	32	MT	
CZ001	15	EPN518	38	ESD		JAB306	32	MT106A	9
CZ007	19	EPN519	38	ESD125	43	JAB306S-IP55	32	MT110A	9
CZ008	19	EPN520	38	ESD226	43	JAB310	32	MT116A	9
CZN005	19	EPN521	38	ESD227	43	JAB310S-IP55	32	MT120A	9
CZN006	19	EPN522	38	ESD240	43	JAB402	32	MT125A	9
		EPN523	38	ESD241	43	JAB403	32	MT132A	9
EE		EPN524	38	ESD263	43	JAB406	32	MT140A	9
EE002	64	EPN525	38	ESD264	43	JAB406S-IP55	32	MT150A	9
EE003	64	EPN526	38	ESD425	44	JAB410	32	MT163A	9
EE100	64	EPN528	38	ESD426	44	JAB410S-IP55	32	MT206A	9
EE101	64	EPN540	38	ESD427	44			MT210A	9
EE110	64	EPN541	38	ESD428	44	JAC		MT216A	9
EE170	64	EPN546	38	ESD440	44	JAC310S-IP55	32	MT220A	9
EE171	64	EPN548	38	ESD463	44	JAC312	32	MT225A	9
EE701	64			ESD464	44	JAC316	32	MT232A	9
EE702	64	ERC				JAC410S-IP55	32	MT240A	9
EE804	71	ERC125	45	ESL		JAC412	32	MT250A	9
EE805	71	ERC216	42	ESL125	43	JAC416	32		
EE806	70	ERC217	42	ESL225	43				

Cat.ref.	Page No.	Cat.ref.	Page No.	Cat.ref.	Page No.	Cat.ref.	Page No.	Cat.ref.	Page No.
MT263A	9	MY216E	8	NC150A	10	NDN350A	11	SPD065N	25
MT306A	9	MY220E	8	NC163A	10	NDN363A	11	SPD140D	25
MT310A	9	MY225E	8	NC200A	10	NDN400A	12	SPD215D	25
MT316A	9	MY232E	8	NC201A	10	NDN401A	12	SPD240D	25
MT320A	9	MY240E	8	NC202A	10	NDN402A	12		
MT325A	9	MY250E	8	NC203A	10	NDN403A	12	SPM	
MT332A	9	MY263E	8	NC204A	10	NDN404A	12	SPM220E	26
MT340A	9	MY301E	8	NC206A	10	NDN406A	12	SPM240E	26
MT350A	9	MY302E	8	NC210A	10	NDN410A	12	SPM265E	26
MT363A	9	MY303E	8	NC216A	10	NDN416A	12	SPM420E	26
MT406A	9	MY304E	8	NC220A	10	NDN420A	12	SPM440E	26
MT410A	9	MY306E	8	NC225A	10	NDN425A	12	SPM465E	26
MT416A	9	MY310E	8	NC232A	10	NDN432A	12		
MT420A	9	MY316E	8	NC240A	10	NDN440A	12	SPN	
MT425A	9	MY320E	8	NC250A	10	NDN450A	12	SPN015R	25
MT432A	9	MY325E	8	NC263A	10	NDN463A	12	SPN040C	25
MT440A	9	MY332E	8	NC300A	10			SPN040D	25
MT450A	9	MY340E	8	NC301A	10	NRN		SPN040N	25
MT463A	9	MY350E	8	NC302A	10	NRN100	13	SPN040R	25
		MY363E	8	NC303A	10	NRN101	13	SPN065R	25
MU				NC304A	10	NRN102	13	SPN140C	25
MU102A	9	MZ		NC306A	10	NRN103	13	SPN165R	24
MU104A	9	MZ201	15	NC310A	10	NRN104	13	SPN215R	25
MU106A	9	MZ202	15	NC316A	10	NRN106	13	SPN240R	25
MU110A	9	MZ203	15	NC320A	10	NRN110	13	SPN265R	24
MU116A	9	MZ204	15	NC325A	10	NRN116	13	SPN415D	25
MU120A	9	MZ205	15	NC332A	10	NRN120	13	SPN415R	25
MU125A	9	MZ206	15	NC340A	10	NRN125	13	SPN440D	25
MU132A	9	MZ209	15	NC350A	10	NRN132	13	SPN440R	25
MU140A	9	MZ214	15	NC363A	10	NRN140	13	SPN465R	24
MU150A	9			NC400A	10	NRN150	13		
MU163A	9	MZN		NC401A	10	NRN163	13	SPV	
MU202A	9	MZN175	15	NC402A	10	NRN200	13	SPV025	25
MU204A	9	MZN175	19	NC403A	10	NRN201	13	SPV025E	25
MU206A	9			NC404A	10	NRN202	13		
MU210A	9	NB		NC406A	10	NRN203	13	SVN	
MU216A	9	NB106A	10	NC410A	10	NRN204	13	SVN121	61
MU220A	9	NB110A	10	NC416A	10	NRN206	13	SVN122	61
MU225A	9	NB116A	10	NC420A	10	NRN210	13	SVN123	61
MU232A	9	NB120A	10	NC425A	10	NRN216	13	SVN124	61
MU240A	9	NB125A	10	NC432A	10	NRN220	13	SVN125	61
MU250A	9	NB132A	10	NC440A	10	NRN225	13	SVN126	61
MU263A	9	NB140A	10	NC450A	10	NRN232	13	SVN127	61
MU302A	9	NB150A	10	NC463A	10	NRN240	13	SVN128	61
MU304A	9	NB163A	10			NRN250	13	SVN129	61
MU306A	9	NB206A	10	NDN		NRN263	13	SVN131	61
MU310A	9	NB210A	10	NDN100A	11	NRN300	13	SVN132	61
MU316A	9	NB216A	10	NDN101A	11	NRN301	13	SVN133	61
MU320A	9	NB220A	10	NDN102A	11	NRN302	13	SVN134	61
MU325A	9	NB225A	10	NDN103A	11	NRN303	13	SVN135	61
MU332A	9	NB232A	10	NDN104A	11	NRN304	13	SVN136	61
MU340A	9	NB240A	10	NDN106A	11	NRN306	13	SVN221	61
MU350A	9	NB250A	10	NDN110A	11	NRN310	13	SVN222	61
MU363A	9	NB263A	10	NDN116A	11	NRN316	13	SVN311	62
MU402A	9	NB306A	10	NDN120A	11	NRN320	13	SVN312	62
MU404A	9	NB310A	10	NDN125A	11	NRN325	13	SVN321	62
MU406A	9	NB316A	10	NDN132A	11	NRN332	13	SVN322	62
MU410A	9	NB320A	10	NDN140A	11	NRN340	13	SVN331	62
MU416A	9	NB325A	10	NDN150A	11	NRN350	13	SVN332	62
MU420A	9	NB332A	10	NDN163A	11	NRN363	13	SVN341	62
MU425A	9	NB340A	10	NDN200A	11	NRN400	13	SVN342	62
MU432A	9	NB350A	10	NDN201A	11	NRN401	13	SVN351	62
MU440A	9	NB363A	10	NDN202A	11	NRN402	13	SVN352	62
MU450A	9	NB406A	10	NDN203A	11	NRN403	13	SVN371	62
MU463A	9	NB410A	10	NDN204A	11	NRN404	13	SVN373	62
		NB416A	10	NDN206A	11	NRN406	13	SVN391	62
		NB420A	10	NDN210A	11	NRN410	13	SVN411	62
MY		NB425A	10	NDN216A	11	NRN416	13	SVN413	62
MY101E	8	NB432A	10	NDN220A	11	NRN420	13	SVN422	62
MY102E	8	NB440A	10	NDN225A	11	NRN425	13	SVN432	62
MY103E	8	NB450A	10	NDN232A	11	NRN432	13	SVN433	62
MY104E	8	NB463A	10	NDN240A	11	NRN440	13	SVN441	62
MY106E	8			NDN250A	11	NRN450	13	SVN452	62
MY110E	8	NC		NDN263A	11	NRN463	13	SVN461	62
MY116E	8	NC100A	10	NDN300A	11			SVN462	62
MY120E	8	NC101A	10	NDN301A	11	SM		SVN463	62
MY125E	8	NC102A	10	NDN302A	11	SM102E	66	SVN464	62
MY132E	8	NC103A	10	NDN303A	11	SM103E	66		
MY140E	8	NC104A	10	NDN304A	11	SM200	66		
MY150E	8	NC106A	10	NDN306A	11	SM201	66		
MY163E	8	NC110A	10	NDN310A	11	SM202	66		
MY201E	8	NC116A	10	NDN316A	11	SM203	66		
MY202E	8	NC120A	10	NDN320A	11				
MY203E	8	NC125A	10	NDN325A	11	SPD			
MY204E	8	NC132A	10	NDN332A	11	SPD015D	25		
MY206E	8	NC140A	10	NDN340A	11	SPD040N	25		
MY210E	8								

Protection devices

the complete solution

Hager offers a wide range of protection devices, such as miniature circuit breakers, auxiliaries and accessories, 2 and 4 pole RCCBs, RCCB auxiliaries, RCBOs, HRC fuse carriers



Miniature circuit breakers	08-14
<hr/>	
Auxiliaries and accessories for MCBs & RCCBs	15
<hr/>	
2 & 4 pole residual current devices	19
<hr/>	
Combined MCB/ RCD (RCBO) 6kA	20
<hr/>	
RCBO electronic	20
<hr/>	
HRC fuse carriers	23
<hr/>	
Surge protective devices type 2	24
<hr/>	
Surge protective devices for general protection	25
<hr/>	
Replacement cartridges for SPDs with plug in cartridge	25
<hr/>	
Monobloc surge protection devices	26
<hr/>	
Enclosed load break switches 20-1600A	32
<hr/>	
IP66 isola	34

Description

Protection and control of circuits against overloads and short circuits in domestic, commercial and industrial applications.

Technical data

C curve tripping
Current rating : 1-63A

Breaking capacity :







4.5kA IEC 60 898
6kA IEC 60 947-2
10KAIC NEMA AB-1
Reference calibration
Temperature : 30°C
Voltage rating : 230/400V
Mechanical endurance :
20 000 operations

Connection capacity :

25mm² rigid conductor
16mm² flexible conductor
Will accept accessories, shunt trips, auxiliary contact.

Approval :

KEMA
ST, SNI, LMK

	Designation	In/A	Width in 17.5mm	Pack qty.	Cat. Ref
 <p>MY106E</p>		Single pole MCB	1	12	MY101E
		2	12	MY102E	
		3	12	MY103E	
		4	12	MY104E	
		6	12	MY106E	
		10	12	MY110E	
		16	12	MY116E	
		20	12	MY120E	
		25	12	MY125E	
		32	12	MY132E	
		40	12	MY140E	
		50	12	MY150E	
		63	12	MY163E	
 <p>MY232E</p>		Double pole MCB	2	6	MY201E
		2	6	MY202E	
		3	6	MY203E	
		4	6	MY204E	
		6	6	MY206E	
		10	6	MY210E	
		16	6	MY216E	
		20	6	MY220E	
		25	6	MY225E	
		32	6	MY232E	
		40	6	MY240E	
		50	6	MY250E	
		63	6	MY263E	
 <p>MY316</p>		Triple pole MCB	3	4	MY301E
		2	4	MY302E	
		3	4	MY303E	
		4	4	MY304E	
		6	4	MY306E	
		10	4	MY310E	
		16	4	MY316E	
		20	4	MY320E	
		25	4	MY325E	
		32	4	MY332E	
		40	4	MY340E	
		50	4	MY350E	
		63	4	MY363E	

Description

Protection and control of circuits against overloads and short circuits in domestic, commercial and industrial applications.

Technical data

MTxxxA = type B tripping
 MUxxxA = type C tripping
 according to IEC 60 898 and BSEN 60-898

Reference calibration
 Temperature : 30°C

Breaking capacity :

6kA IEC 60 898
 10kA IEC 60 947-2
 22KAIC NEMA AB-1
 Voltage rating : 230/400V
 Current rating : 2-63A
 Mechanical endurance :
 20 000 operations





Connection capacity :

25mm² rigid conductor
 16mm² flexible conductor

Will accept accessories, shunt trips, auxiliary contact.

Approval :

KEMA
 SNI
 LMK

Designation	In/A	Width in 17.5mm	Pack qty.	Cat. Ref. B curve	Cat. Ref. C curve
 <p>Single pole MCB</p>	2	1	12	-	MU102A
	4	1	12	-	MU104A
	6	1	12	MT106A	MU106A
	10	1	12	MT110A	MU110A
	16	1	12	MT116A	MU116A
	20	1	12	MT120A	MU120A
	25	1	12	MT125A	MU125A
	32	1	12	MT132A	MU132A
	40	1	12	MT140A	MU140A
	50	1	12	MT150A	MU150A
	63	1	12	MT163A	MU163A
 <p>Double pole MCB</p>	2	2	6	-	MU202A
	4	2	6	-	MU204A
	6	2	6	MT206A	MU206A
	10	2	6	MT210A	MU210A
	16	2	6	MT216A	MU216A
	20	2	6	MT220A	MU220A
	25	2	6	MT225A	MU225A
	32	2	6	MT232A	MU232A
	40	2	6	MT240A	MU240A
	50	2	6	MT250A	MU250A
	63	2	6	MT263A	MU263A
 <p>Triple pole MCB</p>	2	3	4	-	MU302A
	4	3	4	-	MU304A
	6	3	4	MT306A	MU306A
	10	3	4	MT310A	MU310A
	16	3	4	MT316A	MU316A
	20	3	4	MT320A	MU320A
	25	3	4	MT325A	MU325A
	32	3	4	MT332A	MU332A
	40	3	4	MT340A	MU340A
	50	3	4	MT350A	MU350A
	63	3	4	MT363A	MU363A
 <p>Four pole MCB</p>	2	3	4	-	MU402A
	4	3	4	-	MU404A
	6	3	4	MT406A	MU406A
	10	3	4	MT410A	MU410A
	16	3	4	MT416A	MU416A
	20	3	4	MT420A	MU420A
	25	3	4	MT425A	MU425A
	32	3	4	MT432A	MU432A
	40	3	4	MT440A	MU440A
	50	3	4	MT450A	MU450A
	63	3	4	MT463A	MU463A



MU106A



MT240A



MT316A



MU463A

Description

Protection and control of circuits against overloads and short circuits in domestic, commercial and industrial electrical distribution systems.

Technical data

NBxxxA = type B tripping
NCxxxA = type C tripping
according to IEC898 and BSEN 60-898

Breaking capacity :

10kA according to IEC 60 898
15kA according to IEC 60 947-2

30kAIC according to NEMA AB-1
Reference calibration
Temperature : 30°C
Voltage rating : 230/400V
Current rating : 0.5 - 63A
Mechanical endurance :
20 000 operations

Positive contact indication

Red - contacts closed
Green - contacts open
Will accept accessories, shunt trips, auxiliary contact.

Connection capacity

(up to 63A) :
25mm² rigid conductor
16mm² flexible conductor



NB110A NC110A

Designation	In/A	Width in 17.5mm	Pack qty.	Cat. Ref. B curve	Cat. Ref. C curve
Single pole MCB	0.5	1	12	-	NC100A
	1	1	12	-	NC101A
	2	1	12	-	NC102A
	3	1	12	-	NC103A
	4	1	12	-	NC104A
	6	1	12	NB106A	NC106A
	10	1	12	NB110A	NC110A
	16	1	12	NB116A	NC116A
	20	1	12	NB120A	NC120A
	25	1	12	NB125A	NC125A
	32	1	12	NB132A	NC132A
	40	1	12	NB140A	NC140A
	50	1	12	NB150A	NC150A
	63	1	12	NB163A	NC163A



NC210A

Double pole MCB	0.5	2	6	-	NC200A
	1	2	6	-	NC201A
	2	2	6	-	NC202A
	3	2	6	-	NC203A
	4	2	6	-	NC204A
	6	2	6	NB206A	NC206A
	10	2	6	NB210A	NC210A
	16	2	6	NB216A	NC216A
	20	2	6	NB220A	NC220A
	25	2	6	NB225A	NC225A
	32	2	6	NB232A	NC232A
	40	2	6	NB240A	NC240A
	50	2	6	NB250A	NC250A
	63	2	6	NB263A	NC263A



NC310A

Triple pole MCB	0.5	3	4	-	NC300A
	1	3	4	-	NC301A
	2	3	4	-	NC302A
	3	3	4	-	NC303A
	4	3	4	-	NC304A
	6	3	4	NB306A	NC306A
	10	3	4	NB310A	NC310A
	16	3	4	NB316A	NC316A
	20	3	4	NB320A	NC320A
	25	3	4	NB325A	NC325A
	32	3	4	NB332A	NC332A
	40	3	4	NB340A	NC340A
	50	3	4	NB350A	NC350A
	63	3	4	NB363A	NC363A



NB410A

Four pole MCB	0.5	4	3	-	NC400A
	1	4	3	-	NC401A
	2	4	3	-	NC402A
	3	4	3	-	NC403A
	4	4	3	-	NC404A
	6	4	3	NB406A	NC406A
	10	4	3	NB410A	NC410A
	16	4	3	NB416A	NC416A
	20	4	3	NB420A	NC420A
	25	4	3	NB425A	NC425A
	32	4	3	NB432A	NC432A
	40	4	3	NB440A	NC440A
	50	4	3	NB450A	NC450A
	63	4	3	NB463A	NC463A



Description

Protection and control of circuits against overloads and short circuits in commercial and industrial electrical distribution systems.

Technical data

NDNxxxA = type D tripping according to IEC 60 898

Breaking capacity :

10kA according to IEC 60 898
 15kA according to IEC 60 947-2
 30kAIC according to NEMA AB-1
 Reference calibration
 Temperature : 30°C
 Voltage rating : 230/400V
 Current rating : 0.5 - 63A
 Mechanical endurance :
 20 000 operations

Positive contact indication

Red - contacts closed
 Green - contacts open
 Will accept accessories, shunt trippers, auxiliary contact.

Connection capacity

25mm² rigid conductor
 16mm² flexible conductor



NDN116A

Designation	In/A	Width in 17.5mm	Pack qty.	Cat. Ref.
Single pole MCB				
	0.5	1	12	NDN100A
	1	1	12	NDN101A
	2	1	12	NDN102A
	3	1	12	NDN103A
	4	1	12	NDN104A
	6	1	12	NDN106A
	10	1	12	NDN110A
	16	1	12	NDN116A
	20	1	12	NDN120A
	25	1	12	NDN125A
	32	1	12	NDN132A
	40	1	12	NDN140A
	50	1	12	NDN150A
	63	1	12	NDN163A



NDN 232A

Designation	In/A	Width in 17.5mm	Pack qty.	Cat. Ref.
Double pole MCB				
	0.5	2	6	NDN200A
	1	2	6	NDN201A
	2	2	6	NDN202A
	3	2	6	NDN203A
	4	2	6	NDN204A
	6	2	6	NDN206A
	10	2	6	NDN210A
	16	2	6	NDN216A
	20	2	6	NDN220A
	25	2	6	NDN225A
	32	2	6	NDN232A
	40	2	6	NDN240A
	50	2	6	NDN250A
	63	2	6	NDN263A



NDN320A

Designation	In/A	Width in 17.5mm	Pack qty.	Cat. Ref.
Triple pole MCB				
	0.5	3	4	NDN300A
	1	3	4	NDN301A
	2	3	4	NDN302A
	3	3	4	NDN303A
	4	3	4	NDN304A
	6	3	4	NDN306A
	10	3	4	NDN310A
	16	3	4	NDN316A
	20	3	4	NDN320A
	25	3	4	NDN325A
	32	3	4	NDN332A
	40	3	4	NDN340A
	50	3	4	NDN350A
	63	3	4	NDN363A

Miniature circuit breakers

D curve: IEC 60898: 10000 and IEC 60947-2: 15KA



NDN463A

Designation	In/A	Width in 17.5mm	Pack qty.	Cat. Ref.
Four pole MCB	0.5	4	3	NDN400A
	1	4	3	NDN401A
	2	4	3	NDN402A
	3	4	3	NDN403A
	4	4	3	NDN404A
	6	4	3	NDN406A
	10	4	3	NDN410A
	13	4	3	NDN413A
	16	4	3	NDN416A
	20	4	3	NDN420A
	25	4	3	NDN425A
	32	4	3	NDN432A
	40	4	3	NDN440A
	50	4	3	NDN450A
63	4	3	NDN463A	



Type C tripping 25kA ($\leq 25A$)
20kA (32-40A)
15kA (50-63A)

to IEC 60947-2

Current rating:
0.5 to 63A

Tripping curve:
Type C magnetic setting

Applications:
Commercial and industrial applications.

Connection capacity
16mm² flexible conductor
25mm² rigid conductor
Complies with IEC 60 947-2

Accessories
- RCDs add-on blocks
- Auxiliaries



NRN116

Designation	Breaking capacity kA	In/A	Width in 17.5mm	Pack qty.	Cat. Ref.
Single pole MCB					
	25	0.5	1	12	NRN100
	25	1	1	12	NRN101
	25	2	1	12	NRN102
	25	3	1	12	NRN103
	25	4	1	12	NRN104
	25	6	1	12	NRN106
	25	10	1	12	NRN110
	25	16	1	12	NRN116
	25	20	1	12	NRN120
	25	25	1	12	NRN125
	20	32	1	12	NRN132
	20	40	1	12	NRN140
	15	50	1	12	NRN150
	15	63	1	12	NRN163



NRN232

Double pole MCB					
	25	0.5	2	6	NRN200
	25	1	2	6	NRN201
	25	2	2	6	NRN202
	25	3	2	6	NRN203
	25	4	2	6	NRN204
	25	6	2	6	NRN206
	25	10	2	6	NRN210
	25	16	2	6	NRN216
	25	20	2	6	NRN220
	25	25	2	6	NRN225
	20	32	2	6	NRN232
	20	40	2	6	NRN240
	15	50	2	6	NRN250
	15	63	2	6	NRN263



NRN320

Triple pole MCB					
	25	0.5	3	4	NRN300
	25	1	3	4	NRN301
	25	2	3	4	NRN302
	25	3	3	4	NRN303
	25	4	3	4	NRN304
	25	6	3	4	NRN306
	25	10	3	4	NRN310
	25	16	3	4	NRN316
	25	20	3	4	NRN320
	25	25	3	4	NRN325
	20	32	3	4	NRN332
	20	40	3	4	NRN340
	15	50	3	4	NRN350
	15	63	3	4	NRN363



NRN440

Four pole MCB					
	25	0.5	4	3	NRN400
	25	1	4	3	NRN401
	25	2	4	3	NRN402
	25	3	4	3	NRN403
	25	4	4	3	NRN404
	25	6	4	3	NRN406
	25	10	4	3	NRN410
	25	16	4	3	NRN416
	25	20	4	3	NRN420
	25	25	4	3	NRN425
	20	32	4	3	NRN432
	20	40	4	3	NRN440
	15	50	4	3	NRN450
	15	63	4	3	NRN463

Curves "B" and "C" **10000**

IEC 60898-1

10 kA

IEC 60 947-2

In 80 to 125 A

Tripping curves :

"B" magnetic setting between 3 and 5 In

"C" magnetic setting between 5 and 10 In

Use :

Residential, commercial and industrial premises

Connection capacity :

- 35mm² flexible wire
(50mm² possible with some cable end-caps),
- 70mm² rigid wire

KEMA

In conformity with the IEC 60 898-1, 947-2 approved

Designation	In / A	Width in 17.5 mm	Cat. Ref. curve B	Cat. Ref. curve C
-------------	--------	------------------	-------------------	-------------------

Circuit breakers 1 pole



HLF199S



80	1.5	HLE180S	HLF180S
100	1.5	HLE190S	HLF190S
125	1.5	HLE199S	HLF199S

Circuit breakers 2 pole



HLF299F



80	3	HLE280S	HLF280S
100	3	HLE290S	HLF290S
125	3	HLE299S	HLF299S

Circuit breakers 3 pole



HLF399S



80	4.5	HLE380S	HLF380S
100	4.5	HLE390S	HLF390S
125	4.5	HLE399S	HLF399S

Circuit breakers 4 pole



HLF499S













80	6	HLE480S	HLF480S
100	6	HLE490S	HLF490S
125	6	HLE499S	HLF499S

All auxiliaries are common to both single and multi-pole circuit breakers. These auxiliaries are fitted to the left hand side of devices.
 Fault indication, auxiliaries, shunt trips, and under-voltage releases are fitted with a flag indicator that indicates the automatic/remote tripping of the device.

Test mode for CZ001, MZ201, MZ202 : possible to test cabling of auxiliary circuits operation by tripping-over contacts manually. Resetting of contact occurs simultaneously with MCB/RCCB resetting.

CZ001 must be fitted on the RCCB before fitting maximum one additional auxiliary (MZ203 to MZ206). Up to 4 auxiliaries can be fitted on MCB.

	Designation	Description	Width in 17.5mm	Pack qty.	Cat. Ref.
 MZ201	Auxiliary + alarm switch for RCCB	1 module wide for ON/OFF & trip indication	1	1	CZ001
	Auxiliary contacts 6A - 230V~ 3A - 440V~ Allows remote indication of main contact status.	1NO + 1NC auxiliary contact	1/2	1	MZ201
					
 MZ204	Signal contacts 6A - 230V~ 3A - 440V~ Signal contact indicates a fault condition (e.g. MCB tripped on overload or short circuit). flag indicator red - MCB tripped	1NO + 1NC signal contact	1/2	1	MZ202
					
 MZ203	Shunt trip Allows remote tripping of the device	230 - 415 Vac 110 - 130 Vdc	1	1	MZ203
		24 - 48 Vac 12 - 48 Vdc	1	1	MZ204
					
 MZ205	Under voltage release Allows MCB to be closed only when voltage is above 70% of Un. MCB will automatically trip when voltage falls by 35% of Un	48 Vdc 230 Vac	1 1	1 1	MZ205 MZ206
					
 MZ209	Overvoltage auxiliary Protects the installation from permanent overvoltage	230 Vac	1	1	MZ209
	Combined Over & Under-voltage auxiliary Protects the installation from permanent over and under voltage	230 Vac	1	1	MZ214
 MZN175	Locking kit For the dolly of the device supplied without padlock.	This allows locking of the device dolly in the on/off position. will accept two padlocks with hasps of 4.75mm diameter max.		2	MZN175

Type "B" curve

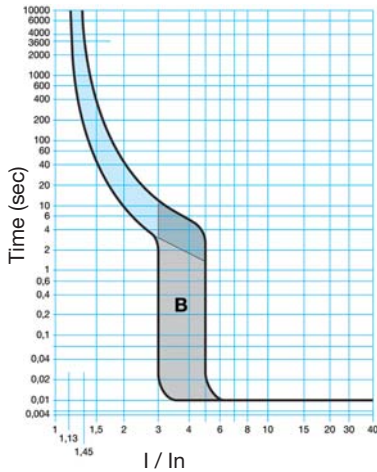

Type "C" curve

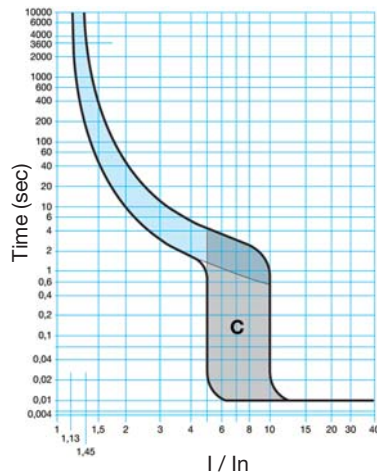

Type "D" curve

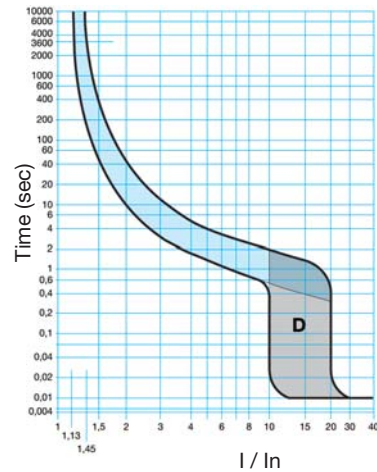

Electrical characteristics

MCB type	MY__E	MT__A	MU__A	NB__A	NC__A	NDN__A	NRN	HLE/F	
Current rating	1 - 63A	6 - 63A	2 - 63A	6 - 63A	0.5 - 63A	0.5 - 63A	6 - 63A	80-125A	
Tripping curve									
B: 3 - 5In									
C: 5 - 10In	C	B	C	B	C	D	C	B / C	
D: 10 - 20In									
Breaking capacity									
EN 60 898 & IEC 898	4.5kA	6kA	6kA	10kA	10kA	10kA	-	10kA	
IEC 947 - 2	6kA	10kA	10KA	15kA	15kA	15KA	15/25kA	10kA	
NEMA AB - 1	10KAIC	22KAIC	22KAIC	30KAIC	30KAIC	30KAIC	30KAIC	-	
Rated voltage - 50/60Hz	230/400Vac (max. 440Vac)							240 / 415Vac	
Isolating voltage	500V								
Electrical endurance	0.5 to 32A		20 000 operations						
	40 to 125A		10 000 operations						
Working temperature	-5°C to +60°C								
Tropicalisation	Treatment 2 with relative humidity 95% at 55°C								

Correction factor

Depending on the model selected some of the breaker is calibrated at a temperature of 30°C in accordance to IEC 898.

Temperature correction

In (A)	30°C	35°C	40°C	45°C	50°C	55°C	60°C
0.5	0.5	0.47	0.45	0.4	0.38	-	-
1	1	0.95	0.9	0.8	0.7	0.6	0.5
2	2	1.	1.7	1.6	1.5	1.4	1.3
3	3	2.8	2.	2.	2.	2.1	1.9
4	4	3.7	3.	3.3	3	2.8	2.5
6	6	5.6	5.3	5	4.6	4.2	3.8
10	10	9.4	8.8	8	7.5	7	6.4
16	16	15	14	13	12	11	10
20	20	18.5	17.5	16.5	15	14	13
25	25	23.5	22	20.5	19	17.5	16
32	32	30	28	26	24	22	20
40	40	37.5	35	33	30	28	25
50	50	47	44	41	38	35	32
63	63	59	55	51	48	44	40
80	80	77.6	75.1	72.6	70	67.2	64.4
100	100	96.6	93.1	89.4	85.6	81.6	77.5
125	125	121.9	118.9	115.7	112.4	109.1	105.6

Grouping factor

(rated current reduce by factor K)

No. of units	K
n = 1	1
2 ≤ n < 4	0.95
4 ≤ n < 6	0.90
6 ≤ n	0.85

Frequency

Thermal - Unchanged

Magnetic - Value multiplied by coefficient K

F (Hz)	17Hz - 60Hz	100Hz	200Hz	400Hz
K	1	1.1	1.2	1.5

Installation

Working position : vertically, horizontally or flat.

Supply : feed from either top or bottom terminals.

i^2t characteristics curve

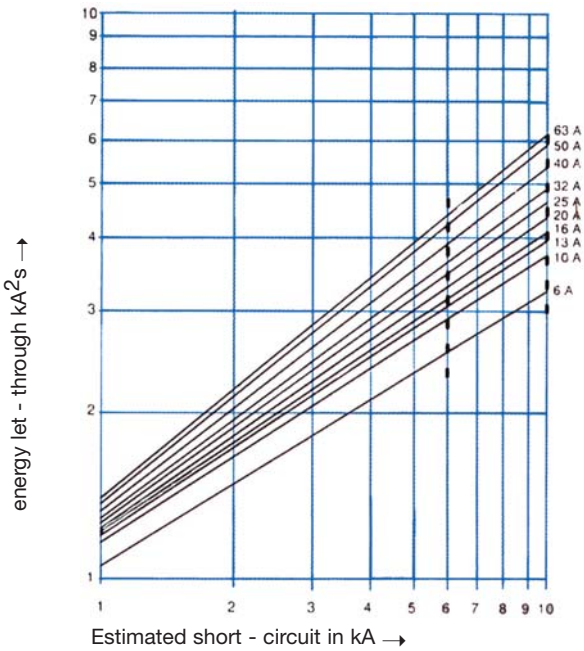

Current limitation curve

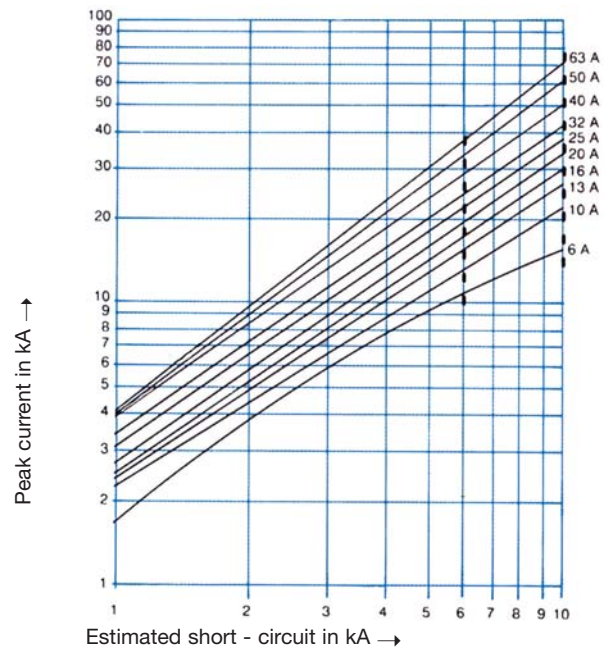

Power loss

The power loss of MCB's is closely controlled by the standards and is calculated on the basis of the voltage drop across the main terminals measured at rated current. The power loss of Hager circuit breakers is very much lower than that required by the IEC Standard, so in consequences run cooler and are less affected when mounted together.

The table below gives the watts loss per pole at rated current.

MCB rated current (A)	0.5	1	2	3	4	6	10	16	20	25	32	40	50	63	80	100	125
Watt loss per pole (W)	1.3	1.5	1.7	2.1	2.4	2.7	1.8	2.6	2;8	3.3	3.9	4.3	4.8	5.2	5	5.5	8

DC applications

Because of their quick make and break design and excellent arc quenching capabilities Hager circuit breakers are suitable for use on DC. When selecting a circuit breaker for any DC application it is necessary to consider two main points.

1. rated current

The thermal time/current characteristics is unaffected so that the circuit breaker will carry its rated current and operate within its designated thermal time/current zone at 40°C Derating for higher ambient temperatures and grouping apply exactly the same as AC applications. The instantaneous magnetic trip is affected however, becoming less sensitive, requiring 2 times the AC operating current. The table below shows the upper and lower limits of both B and C instantaneous characteristic curves for 50Hz C and DC applications. Thermal unchanged. Magnetic trip increased as table below.

Characteristics curve	B		C	
	50Hz	DC	50Hz	DC
magnetic trip	3In	3In	5In	5In
I _{rm} 1	3In	3In	5In	5In
I _{rm} 2	5In	7.5In	10In	15In

2. system voltage

The system voltage and the type of system determines the number of poles required to provide the necessary breaking capacity and arc control. The table below gives the maximum DC voltage and breaking capacity for one pole or two poles connected in the series; The positioning of these breaking poles in the system depends on whether the system is earthed or insulated and if it is earthed whether one polarity is earthed or the centre point is earthed.

MCB	Breaking capacity			Magnetic tripping
	1 poles in series/60V	2 poles in series/250V	4 poles in series/250V	
MY	10kA	10kA	-	5 - 15In
MT	15kA	15kA	-	3 - 7.5In
MU	15kA	15kA	-	5 - 15In
NB	20kA	20kA	20kA	3 - 7.5In
NC	20kA	20kA	20kA	5 - 15In
NDN	15kA	15kA	15kA	13 - 28In
NRN	20kA	20kA	20kA	5 - 15In
HLE	10kA	10kA	10kA	3 - 7.5In
HLF	10kA	10kA	10kA	5 - 15In

Functions

Tripping and indication auxiliary contacts are common to the range of Hager MCBs and RCCBs. They should be mounted on the left hand side of the device.

Auxiliary contact MZ201

Allows remote indication of the status of the device contacts to which it is associated.

Alarm contact MZ202

The alarm or signal contact will provide indication if the breaker trips under fault conditions

Note

Default indication auxiliaries and shunt trips or under voltage releases are fitted with tripping indications and reset facility.

MZN203 / MZN204 shunt trip

Allows tripping of the device by feeding the coil. It is fitted with internal contacts which allow it to be fed by an impulse or latched feed.

The contacts also allow for remote indication of operation.

MZN205 / MZN206 under voltage release

Allows the MCB to trip when the voltage drops or by pressing a remote off switch (ie emergency stop).

Emergency switch - off with under voltage release

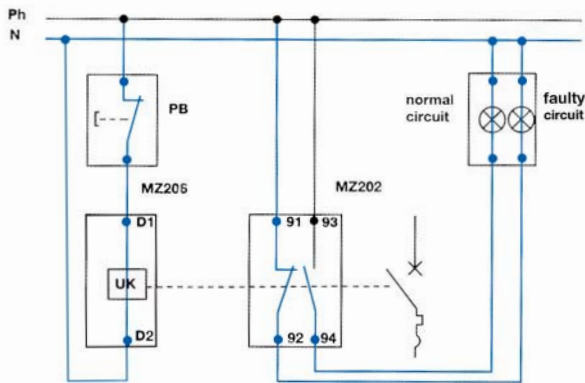

Note : control circuit must be protected using a maximum 6A curve C MCB.

Sizes

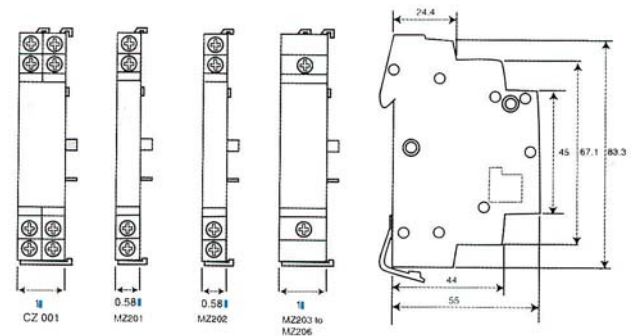

Recapitulative table

	MZ201	MZ202	CZ001	MZ203	MZ204	MZ205	MZ206
	1O + 1C	1O + 1C	2X				
	230V~ 6A	230V~ 6A	1O + 1C				
	440V~ 3A	440V~ 3A	230V~ 6A				
			400V~ 3A	230 to 415V~	24 to 48V~	48V	230V~
				110 to 130V=	12 to 48V=		
				50Hz	50Hz	50Hz	50Hz

Grouping / combination of several auxiliaries

On 2, 3 and 4 pole MCBs it is possible to associate 3 auxiliaries - 2 indication auxiliaries and 1 release auxiliary. In this case, it is important to first fix the indication auxiliary (MZ 201 and MZ 202) and then the release auxiliary (MZ 203/204 and MZ 205/206)

Description

To open a circuit automatically in the case of an earth leakage fault between phase and earth and / or neutral greater or equal to 10, 30, 100, 300 or 500mA; use in domestic, commercial and industrial installations.

Technical data

Nominal voltage :
 2 pole 127/230V - 50Hz
 4 pole 230/400V - 50Hz
 specifications : IEC 61008-1 SS97

Connection capacity :

16-63A rigid 25mm²
 flexible 16mm²
 80-100A rigid 50mm²
 flexible 35mm²

Ambient temperature range :
 -5 to + 40°C

Positive contact indication :

Mechanical indicator, appearing on the front face of the RCCB, linked to the contacts shows the positive opening of all poles,
 red = contacts closed
 green = contacts open

Earth fault indicator

Mechanical indicator appearing on the front face of the RCCB to differentiate between tripping and off position
 yellow - tripped

Nuisance tripping

All the RCCBs are protected against transient voltages (lightning, line disturbances) and transient currents (from high capacitive circuits).
 DC sensitive RCCBs or time delay devices are available, please consult us.
 You also have the possibility to install the following accessories :
 electrical auxiliaries
 terminal cover kit
 locking kit



CD240B



CD440B

	Sensitivity IΔn	Current	Pack qty.	Cat.Ref. 2 poles	Pack qty.	Cat. Ref. 4 poles
High sensitivity	30mA	16A	1	CD216B	-	-
		25A	1	CD225B	1	CD425B
		40A	1	CD240B	1	CD440B
		63A	1	CD263B	1	CD463B
		80A	1	CD280B	1	CD482B
		100A	1	CD284B	1	CD485B
Medium sensitivity	100mA	25A	1	CE225B	1	CE425B
		40A	1	CE240B	1	CE440B
		63A	1	CE263B	1	CE463B
		80A	1	CE280B	1	CE480B
		100A	1	CE284B	1	CE484B
Low sensitivity	300mA	25A	1	CF225B	1	CF425B
		40A	1	CF240B	1	CF440B
		63A	1	CF263B	1	CF463B
		80A	1	CF280B	1	CF480B
		100A	1	CF284B	1	CF484B
Low sensitivity	500mA	25A	1	CG225B	1	CG425B
		40A	1	CG240B	1	CG440B
		63A	1	CG263B	1	CG463B
		80A	1	CG280B	1	CG480B
		100A	1	CG284B	1	CG484B
Terminal cover kit (1 set = 2 covers)		for RCCBs 2I		16 to 63A	10 sets	CZN005
		for RCCBs 4I		16 to 63A	10 sets	CZN006
		for RCCBs 2I		80 to 100A	10 sets	CZ007
		for RCCBs 4I		80 to 100A	10 sets	CZ008
Locking kit :					1	MZN175

Description

Compact protection devices which provide MCB overcurrent protection and RCCB earth leakage protection in a single unit.

Specification

IEC 61009-1

Protected against transient voltages (lightning, line disturbances,...) and transient currents (from high capacitive circuits)



Technical data :

The units are available with current ratings of 6A, 10A, 16A, 20A, 25A, 32A and 40A. The device switches both the phase and neutral conductors. All ratings have 10mA, 30mA, 100mA or 300mA earth leakage protection. The units feature indicators which show whether tripping is due to an overcurrent or earth leakage fault.

Voltage rating - 127-230V
Current rating - 6-40A.

Mechanical life :

2 000 operations

6kA IEC 61 009-1
10kA IEC 60 947-2

Type AC

Connection capacity

Rigid conductor 25mm²
Flexible conductor 16mm²



AD616B

Designation	Sensitivity IDn	In/A	Breaking capacity	Width in ■ 17.5mm	Pack qty.	Cat. Ref. type C
RCBO 1P+N	30mA	10	6kA	2	1	AD610B
		16		2	1	AD616B
		20		2	1	AD620B
		25		2	1	AD625B
		32		2	1	AD632B
		40		2	1	AD640B

RCBO electronic

Description

Compact one module protection devices which combine the overcurrent functions of an MCB with the earth fault functions of an RCD. A range of sensitivity and current ratings are available for use in commercial and industrial applications

Technical data

Specification complies with IEC 61 009-2

Sensitivity (fixed)

10 - 30 - 100 - 300 mA

Terminal capacities :

1 module type - 16mm² rigid
10mm² flexible

Operation temperature :

-25°C to +55°C

Features

1 module devices provide a compact solution for installation in consumer units, Invicta TP+N distribution boards, and din rail enclosures. These devices are 1P & solid neutral.

Operating voltage

110 - 230 V AC

Flying neutral lead length 700mm



AD110

Sensitivity IΔn mA	Breaking capacity	In/A	Width in ■ 17.5mm	Pack qty.	Cat. Ref. type C
30mA	6kA	6A	1	1	AD119
		10A	1	1	AD120
		16A	1	1	AD122
		20A	1	1	AD123
		25A	1	1	AD124
		32A	1	1	AD125
		40A	1	1	AD126
		45A	1	1	AD127
		50A	1	1	AD128

Residual current devices

A residual current device (RCD) is the generic term for a device which monitors the current in the line conductor and the neutral conductor of a circuit in an earthed system.

The drawing opposite shows how a toroid is located around the line and neutral conductors to measure the magnetic fields created by the current flowing in these conductors. The sum of the magnetic fields set up by these currents (which takes into consideration both the magnetic and phase relationship of the currents) is detected by the toroid.

In a normal healthy circuit the vector sum of the current values added together will be zero. Current flowing to earth, due to a line earth fault, will return via the earth conductor, and regardless of load conditions will register as a fault. This current flow will give rise to a residual current (I_{res}) which will be detected by the device.

It is most important that the line and neutral conductors are passed through the toroid. A common cause of nuisance operation is the failure to connect the neutral through the device.

RCCBs work just as well on three phase or three phase and neutral circuits, but when the neutral is distributed it must pass through the toroid.

RCCB are not suitable for use on DC systems and unearthed networks.

RCCBs - domestic installation

RCCBs can be installed in two ways :

1. whole house protection
2. selective protection

Whole house protection is provided typically by a consumer unit where the RCCB device serves as the main switch. Although very popular this suffers from a disadvantage : all circuits are disconnected in the event of fault. Selective protection can be provided by associating the RCCB with identified high risk circuits by adopting one or more of the following :

Split busbar consumer unit

All circuits are fed via an overall isolator and selected circuits fed additionally via the RCCB. Typical circuits fed direct are lighting, freezer, storage heating ; and circuits fed via the RCCB are socket outlets, garage circuits. This concept minimises inconvenience in the event of fault.

Whole ring circuit

A 30mA device adjacent to the consumer unit, which provides protection for the downstairs ring circuit, provides an easy installation with protection for all associated socket outlets. This represents the best solution for upgrading existing installations.

Nuisance tripping

All Hager RCCBs incorporate a filtering device preventing the risk of nuisance tripping due to transient voltages (lightning, line disturbances on other equipment...) and transient currents (from high capacitive circuit).

Check for the symbol :

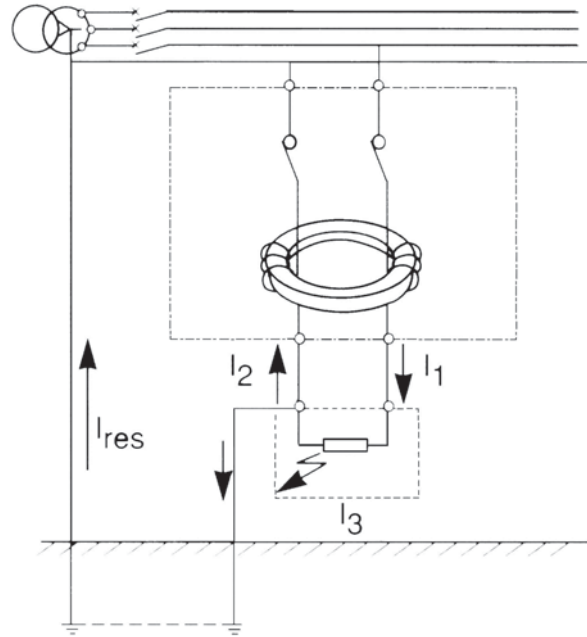

Pulsating DC fault current sensitive

Increasingly, semi-conductors are also extensively used in computers, VDUs, printers, plotters,... all of which may be fed from the main electrical supply. The presence of semi-conductors may result in the normal sinusoidal AC waveform being modified. For example, the waveform may be rectified or, as in asymmetric phase control devices, the waveform may be chopped. The resulting waveforms are said to have a pulsating DC component.

In the event of an earth fault occurring in equipment containing conductor devices, there is a probability that the earth fault current will contain a pulsating DC component.

Standard types of RCCB may not respond to this type of earth fault current and the intended degree of protection will not be provided.

Check for symbol :

Hager provide a range of pulsating d.c. sensitive devices for this type of application.

Tripping characteristics

Type	$I_n(A)$	$I_{\Delta n}(A)$	Standard values of break time(s) and non-actuating time(s) at a residual current (I) equal to :					
			$0.5I_{\Delta n}$	$I_{\Delta n}$	$2I_{\Delta n}$	$5I_{\Delta n}$	500A	
general	any value	≤ 0.03	no trip	0.1s	0.1s	0.04s	0.04s	max. break times
		> 0.03	no trip	0.3s	0.15s	0.04s	0.04s	max. break times

Protection against shock outside the equipotential bonding zone

Bonding conductors are used in an installation to maintain metallic parts, as near as possible, to the same potential as earth. Working with portable equipment outside this equipotential bonding zone, e.g. in the car park of a factory, introduces additional shock hazards. Socket outlets rated 32A or less 'which may be reasonably expected to supply portable equipment for use outdoors' should have at least one socket nominated for outdoor use. This socket should be equipped with RCC protection unless fed from an isolating transformer or similar device, or fed from a reduced voltage.

Protection in special situations (IEE wiring regulation)
The use of RCCBs is obligatory or recommended in the following situations :

- Caravans : 30mA RCCBs should be used
- TT systems
- Swimming pools : 30mA RCCB for socket outlets in zone B obligatory; recommended in zone C.
- Agricultural and horticultural : 30mA RCCB for socket outlets and for the purpose of protection against fire, RCCB 0.5A sensitivity.
- Construction sites : 30mA RCCB recommended

Portable equipment

With the exception mentioned above, where a socket is specifically designated for work outside the equipotential bonding zone, the Wiring Regulations demand the use of RCCBs to protect the users of portable equipment. It is widely recognised that their use has made a significant contribution to safety in the workplace and the home.

Protection against fire hazards

The provisions in the Wiring Regulations for protection against shock by indirect contact ensure rapid disconnection under earth fault assuming the fault has negligible impedance. Under such conditions the fault current, as we have seen, is sufficiently great to cause the overcurrent protection device to quickly disconnect the fault. However high impedance faults can arise where the fault current is sufficient to cause considerable local heat without being high enough to cause tripping of the overcurrent protective device. The heat generated at the point of the fault may initiate a fire long before the fault has deteriorated into a low impedance connection to earth.

The provision of residual current protection throughout a system or in vulnerable parts of a system will greatly reduce the hazard of fire caused by such faults.

PEN conductors

The use of RCCBs in PEN conductors is prohibited. A PEN conductor is a single conductor combining the functions of neutral conductor and protective conductor. This being so, when the PEN conductor is taken through the torroid of an RCCB, earth faults will go undetected because the return path for the earth fault current is included in the residual sum.

Use of Hager RCCBs on 3 phase 3 wire systems

The Hager range of 4 pole RCCBs can be used to provide residual current protection of 3 phase, 3 wire circuits (no neutral).

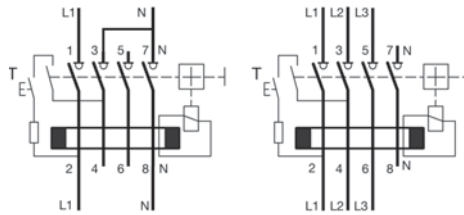

Supply entry
Top or bottom feed.

RCCBs /MCBs co-ordination

RCCBs	with MCBs				
	MY	MT/MU	NB/ HLE	NC/ HLF	NDN
	1-63A	2-63A	6-100A	0.5-100A	6-63A
	C	B/C	B	C	D
2 poles					
16A	4.5kA	6kA	10kA	10kA	10kA
25A	4.5kA	6kA	10kA	10kA	10kA
40A	4.5kA	6kA	10kA	10kA	10kA
63A	4.5kA	6kA	10kA	10kA	10kA
80A	4.5kA	6kA	10kA	10kA	10kA
100A	4.5kA	6kA	10kA	10kA	10kA
4 poles					
16A	4.5kA	6kA	10kA	10kA	10kA
25A	4.5kA	6kA	10kA	10kA	10kA
40A	4.5kA	6kA	10kA	10kA	10kA
63A	4.5kA	6kA	10kA	10kA	10kA
80A	4.5kA	6kA	10kA	10kA	10kA
100A	4.5kA	6kA	10kA	10kA	10kA

Positive contact indication

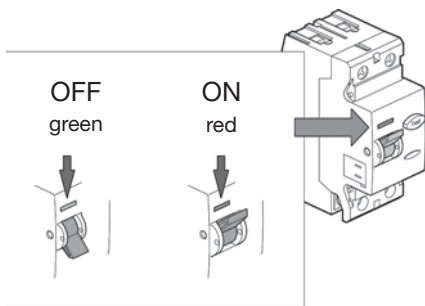

TEST : test regularly : RCCB must trip.

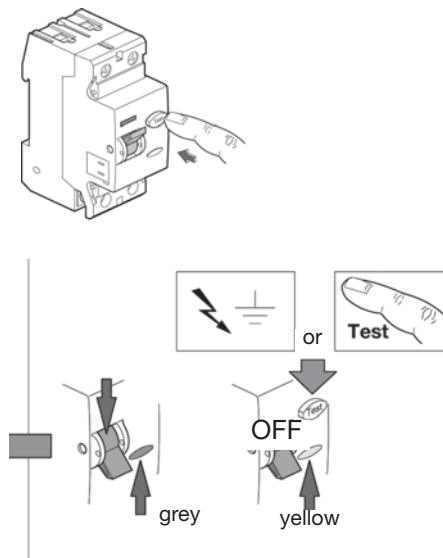

Fuse carrier 32 Amps max.

Protection and control of circuits against overloads and

Short-circuit :

- In single or three phase subcircuits
- Suitable for fuses which comply with IEC 269
- Rating voltage : 415 V a.c.
250 V d.c.

- Fusing factor : class Q1
- Rated breaking capacities;
80kA at 415 V a.c.
40kA at 250 V d.c.
- Complies with
IEC 60 269-2, 2-1
- For spare cartridge fuses
10.3 x 38mm



LS501

Designation	Description	Width in ■ 17.5mm	Pack. qty.	Cat. Ref.
Fuse carriers For cylindrical cartridge fuses 10.3 x 38mm (supplied without fuse)	1P	1	12	LS501
	1P + N	2	12	LS512
	2P	2	6	LS502
	3P	3	6	LS503
	3P + N	4	3	LS504
	1P with indicating light	1	12	LS531

SPDs with plug in cartridge with very high, high and medium discharge current capacity (65 kA, 40 kA and 15 kA).

- SPDs with plug in cartridge ensure :
- General protection of electrical or electronic equipment,
 - Protection in common and differential mode for domestic, industrial and commercial buildings.

Common characteristics :
 SPDs with base and cartridges. Available in 2 versions :

- SPDs with base and plug in cartridges with an end of life indication LED
- SPDs with base and auxiliary contact for remote signalling and plug in cartridges with reserve protection indicator .

This version, with reserve indicator, shows the intermediary state, with indication of the need to change the cartridge before disconnection, but keeps the maximal protection capacity till the end.

For remote signalling, an auxiliary contact (R version) is used to report the information of condition indication until the end of life of the product.



The cartridge allows simple replacement without the need to cut-off the power supply

- SPDs are equipped with integrated thermic and dynamic disconnection

- Connection capacity of terminal blocks, (L, N/E) :
- 25mm² flexible conductor,
- 35mm² rigid conductor

For auxiliary contact :

- 0.5mm² mini
- 1.5mm² maxi
- Degree of protection : IP 203 (in enclosure).

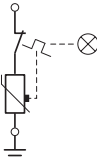
Designation	Characteristics	Width in ■ 17.5mm	Cat. Ref.
 SPN265R	SPDs with plug in cartridge I max. 65kA Un :230/400 V ~ 50/60 Hz	1	SPN165R
	I max. 65kA Un: 230/400 V ~ 50/60 Hz	2	SPN265R
 SPN465R	I max. 65kA Un: 230/400 V ~ 50/60 Hz	4	SPN465R
		4	SPN465R

	Designation	Characteristics	Width in 17.5mm	Cat. Ref.
<p>SPN240R</p>	<p>SPDs with plug in cartridge</p> <p>I max. 40 kA Un : 230/400 V ~ 50/60 Hz</p>	- Single pole 1 Ph Up : 2 kV at In	1	SPN140C
		- Single pole 1 Ph Up : 1.2 kV at In	1	SPD140D
		- 2 poles 1 Ph + N with reserve indicator and remote signalling Up : 1.2 kV at In	2	SPN240R
		- 2 poles 1 Ph + N Up : 1.2 kV at In	2	SPD240D
		- 4 poles 3 Ph + N with reserve indicator and remote signalling Up : 1.2 kV at In	4	SPN440R
		- 4 poles 3 Ph + N Up : 1.2 kV at In	4	SPD440D
<p>SPD415D</p>	<p>SPDs with plug in cartridge</p> <p>I max. 15 kA Un: 230/400 V ~ 50/60 Hz</p>	- 2 poles 1 Ph + N with reserve indicator and remote signalling Up : 1.0 kV at In	2	SPN215R
		- 2 poles 1 Ph + N Up : 1.0 kV at In	2	SPD215D
		- 4 poles 3 Ph + N with reserve indicator and remote signalling Up : 1.0 kV at In	4	SPN415R
		- 4 poles 3 Ph + N Up : 1.0 kV at In	4	SPD415D

Replacement cartridges for SPDs with plug in cartridge

Replacement cartridges
The cartridge allows simple replacement without the need to cut-off the power supply.

Cartridges are available for all discharge currents (65 kA, 40kA, 15kA) with or without reserve protection indication.

A keying system exists to prevent a line cartridge being interchanged by mistake with a neutral and vice versa

	Designation	Characteristics	Cat Ref..
<p>SPN065R</p>	<p>Replacement cartridges</p>	Phase for : SPN265R, SPN465R	SPN065R
		SPN140C	SPN040C
		SPN240R, SPN440R	SPN040R
		SPD140D, SPD240D, SPD440D	SPD040D
		SPN215R, SPN415R	SPN015R
		SPD215D, SPD415D	SPD015D
<p>SPN065N</p>	<p>Remark : For a replacement of cartridges, choose only the same reference as the previous cartridge.</p>	Neutral for: SPN 265R, SPN465R,	SPN065N
		SPN240R, SPN440R,	SPN040N
		SPN215R, SPN415R SPDxxxD	SPD040N
<p>SPV025</p>	<p>Cartridge for photovoltaic SPDs Ucpv ≤ 1000V DC</p>	polarized +/- for SPV325	SPV025
		earth for SPV325	SPV025E

Description

Thanks to these characteristics, the new range of monobloc SPDs is particularly adapted for the residential and commercial application.

These SPDs can ensure the main protection of equipment and ensure the main protection of equipment and ensure both common and differential mode. The end of life protection is ensured by a thermal disconnect and clearly indicates with a visual indication window.

Connection capacity:

- 25mm² flexible cables
- 35mm² rigid cables

SPDs are approved according to IEC/EN 61643



SPM240E



SPM440E

Designation	Characteristics	Width in 17.5mm	Pack qty	Cat. Ref.
Monobloc SPDs I _{max} = 65kA U _n = 230 / 400V ~	1 Ph+N I _n = 35kA U _p = 1.8V to I _n	2	1	SPM265E
	3 Ph + N I _n = 35kA U _p = 1.8V to I _n	4	1	SPM465E
Monobloc SPDs I _{max} = 40kA U _n = 230 / 400V ~	1 Ph+N I _n = 20kA U _p = 1.5V to I _n	2	1	SPM240E
	3 Ph + N I _n = 20kA U _p = 1.5V to I _n	4	1	SPM440E
Monobloc SPDs I _{max} = 20kA U _n = 230 / 400V ~	1 Ph+N I _n = 10kA U _p = 1.3V to I _n	2	1	SPM220E
	3 Ph + N I _n = 10kA U _p = 1.3V to I _n	4	1	SPM420E

Installation example

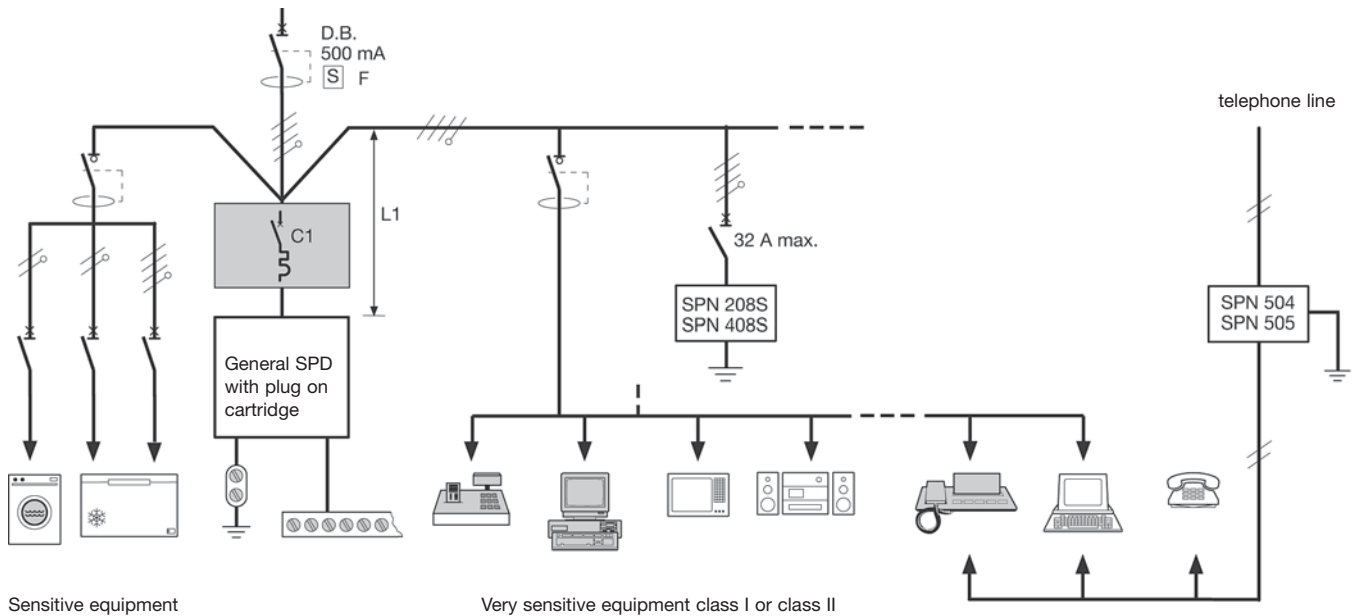

Some installation rules for SPDs

- General SPD protects the whole installation by diverting the lightning current to the earth. Fitted in directly downstream the type S differential function or delayed for system TT and TN-S.
- The cable length L1 must be reduced to less than 0,5m
- The resistance of the earth connection must be weakest possible (approx. 10) and only one is requested by installation,
- SPDs SPN 208 and SPN 408S protect very sensitive devices of class I and class II.
- A cable length of at least 1m is requested between general and secondary SPD to ensure a minimum impedance in order to avoid the simultaneous bringing into conduction of both SPDs,
- SPDs SPN 504 and SPN 505 protect analog or digital telephone lines from very sensitive receivers.

Note.: When SPD is fitted downstream of RCD, the system should preferably be selection (with time delay) to avoid nuisance tripping.

Choice of disconnection device

The chosen device is an MCB

Selection chart for disconnection device according to the SPD type

General SPD	C1 (1)
SPN 165P	32 A curve C
SPN 265R	
SPN 465R	
SPN 140C - SPD 140D	32 A curve C
SPN 240R - SPD 240D	
SPN 440R - SPD 440D	
SPN 215R - SPD 215D	32 A curve C
SPN 415R - SPD 415D	

(1) The breaking capacity of MCB must be chosen according to the short circuit intensity at the head of the installation and according to the number of poles (1,2 or 4)

Distressing of SPD

Successive discharging of current due to lightning reduces progressively the performance of SPD's, with the consequence of a possible short circuit for the installation. For this reason, all our SPDs are fitted with an automatic thermal and dynamic disconnection device LED on front indicates the good working of the device :

- For normal version :
Green = OK Red = replacement
- For version with reserve indicator :
Green = OK Yellow = caution Red = replacement
- For version with electric LED for SPDs for fine protection
Green = OK LED off = replacement

Warranty
Warranty can not be applied for SPDs as their life expectancy depends on the perturbation level absorbed to protect the electric installation.

SPDs with plug in cartridge

Presentation of 1 pole and multi pole SPDs :
Available in two versions :

- Base with an auxiliary contact and cartridges with reserve indicator
- Base without auxiliary contact and cartridges with end of life LED

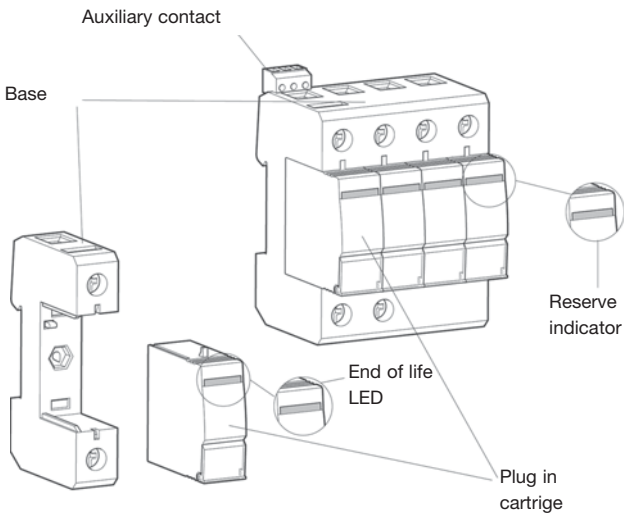

Neutral plug in cartridges can not be fitted in slots for phase cartridges and visa versa

On the front of the cartridge, a mechanical LED indicates the state of SPD

With reserve indicator



End of live LED

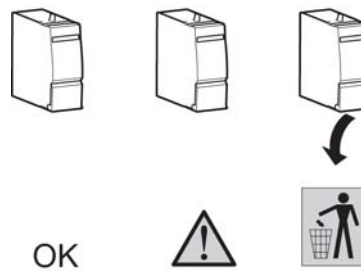

Auxiliary contact for signalling and remote monitoring

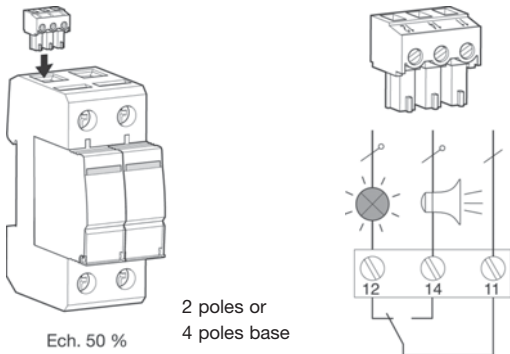

Auxiliary contact connection capacity	mini maxi	0,5 mm ² 1.5 mm ²	
Remote signalling	voltage nominal current	230 V~ 1 A	250 V ... 0,1 A

Connection diagrams

Single pole SPDs : SPN1xx - SPD1xx
Protection only in common mode

IT / TN-C

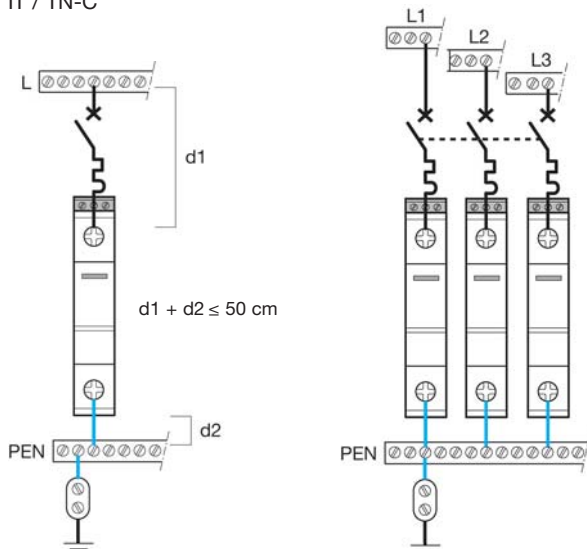

Multi pole SPDs : SPN2xx - SPN4xx - SPD2xx - SPD4xx
protection is assured in both common and differential modes without adding devices

TT / TN-S

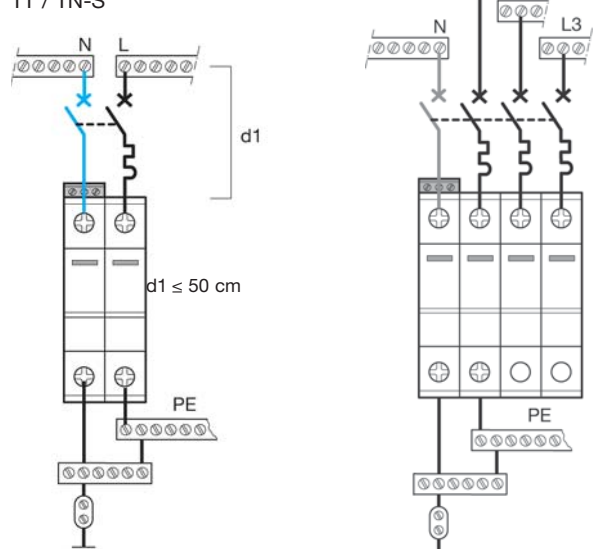

Technical characteristics of secondary SPDs (fine protection)

Installation exposure level (risk)		medium	medium
Installation of SPDs		in parallel	in parallel
Nominal voltage Un frequency		230 V~ 50/60 Hz	230 V~ 50/60 Hz
Max. continuous operating voltage Uc		440 V	275 V
Voltage protection level Up		2 kV	1,2 kV
Discharge current capacity 8/20 μ s wave	nominal current In max. current Imax	15 kA 40 kA	15 kA 40 kA
Degree of protection		IP 20	IP 20
Short circuit resistance Icc (MCB - curve C)		20 kA - 32 A	20 kA - 32 A
Temperature	working storage	-20°C to +60°C -40°C to +70°C	-20°C to +60°C -40°C to +70°C
End of live LED		yes	yes
Reserve indicator + auxiliary contact		-	-
Domestic building	collective/individual industrial/commercial	yes yes	yes yes
Earthing systems		IT, TN-C	IT, TN-C
Max. connection capacity (Ph, N, E)	flexible rigid	25 mm ² 35 mm ²	25 mm ² 35 mm ²
screw head		PZ2	PZ2

Technical characteristics of multipole SPDs

References		SPN265R - SPN465R	SPN240R, SPN440R SPD240D, SPD440D	SPN215R, SPN415R SPD215D, SPD415D
Installation exposure level (risk)		very high	medium	low
Installation of SPDs		in parallel	in parallel	in parallel
Nominal voltage Un frequency		230/400 V~ 50/60 Hz	230/400 V~ 50/60 Hz	230/400 V~ 50/60 Hz
Max. continuous operating voltage Uc	between Phase / Neutral between Neutre / PE	255 V 275 V	255 V 275 V	255 V 275 V
Protection mode	common differential	yes yes	yes yes	yes yes
Voltage protection level Up		1,5 kV	1,2 kV	1,0 kV
Discharge current capacity 8/20 μ s wave	nominal current In maxial current Imax	20 kA 65 kA	15 kA 40 kA	5 kA 15 kA
Degree of protection		IP 20		
Short circuit resistance Icc	(MCB - curve C)	20 kA - 32 A	20 kA - 32 A	10 kA - 32 A
Working temperature		-40°C à +60°C		
End of life LED		-	SPN 240D - SPN 440D	SPN 215D - SPN 415D
Reserve indicator + auxiliary contact		SPN 265R - SPN 465R	SPN 240R - SPN 440R	SPN 215R - SPN 415R
Domestic buildings	collective / individual industrial / commercial	yes yes		
Earthing systems		TT TN - S	TT TN - S	TT TN - S
Connection capacity (Ph, N, E)	flexible rigid	25 mm ² 35 mm ²		
Screw head		PZ2		

Switch disconnectors



The advantages for you :

- Easy to install
- Positives action door handle
- Lockable off

Technical data :

- IEC 60947-3
- Robust 1.2 mm steel enclosure

Expert tips

1



- 2.0 mm (up to 400A)
- 2.5 mm (up to 630A - 800A)
- Knock outs and removable gland plate

3



Lockable off

2



Robust 1.2 mm steel enclosure

4



Terminal cover

Description

The range of enclosed FBS have been designed to match the TP& N range of distribution boards. The number of enclosure sizes have been optimized, to ensure an easy installation. The FBS products are designed to protect and isolate individual circuits. The range is presented

in surface mounting enclosures and includes 2 versions of boxes:

- TPN 20-1600A (14 ratings)
- TPSN 20-1600A (14 ratings)

Delivered with

- load break switch
- plain door
- extended rotary handle

Technical data:

- Indoor
- Outdoor IP55
- nominal current (In): 20A up to 1600A
- rated voltage (Ue): 415V AC
- utilisation category: AC23A
- color: epoxy powder coating RAL 9002
- metallic enclosure
- 1.2mm thickness CR4 steel
- extra cabling space

Comply with

- BS EN 61 439-1,
- BS EN 61 497-3,
- IEC 61 497-3
- LBS Sequence 1 & 3
- FCS Sequence 1 & 4



JAB316

Designation Enclosed LBS	In A	Utilisation Category	Cat. Ref. Trip pole & neutral	Cat. Ref. Trip pole & switched neutral
Triple pole & neutral	20A	AC23A	JAB302	JAB402
	32A	AC23A	JAB303	JAB403
	63A	AC23A	JAB306	JAB406
	100A	AC22A	JAB310	JAB410
	125A	AC23A	JAC312	JAC412
	160A	AC23A	JAC316	JAC416
	200A	AC23A	JAE320	JAE420
	250A	AC23A	JAE325	JAE425
	315A	AC22A	JAG331	JAG431
	400A	AC22A	JAG340	JAG440
	630A	AC22A	JAH363	JAH463
	800A	AC23A	JAH380	JAH480
	1250A	AC23A	JAH390	JAH490
	1600A	AC23A	JAH392	JAH492



JAG440

Designation Enclosed LBS	In A	Cat. Ref. TP & N	Cat. Ref. TP & SW N
IP55	63A	JAB306S-IP55	JAB406S-IP55
	100A	JAB310S-IP55	JAB410S-IP55
	160A	JAC316S-IP55	JAC416S-IP55
	200A	JAE320S-IP55	JAE420S-IP55
	250A	JAE325S-IP55	JAE425S-IP55
	315A	JAG331S-IP55	JAG431S-IP55
	400A	JAG340S-IP55	JAG440S-IP55
	630A	JAH363S-IP55	JAH463S-IP55

Designation Enclosed LBS	In A	Utilisation Category	Cat. Ref.
Cable extension boxes triple pole & triple pole switched neutral	125A , 160A 200A , 250A , 315A , 400A 630A , 800A		JZA700 JZA701 JZA702
Auxiliary contact 1NO + 1NC	20A to 100A 100A to 160A 200A to 630A 800A to 1600A		HZ021 HZ022 HZ023 HZ025

Terminal cover	In	3P	4P
	125A to 200A	HZC201	HZC202
	250A to 400A	HZC203	HZC204
	630A	HZC205	HZC206
	800A	HZ036	HZ046
	1250A to 1600A	HZ037	HZ047

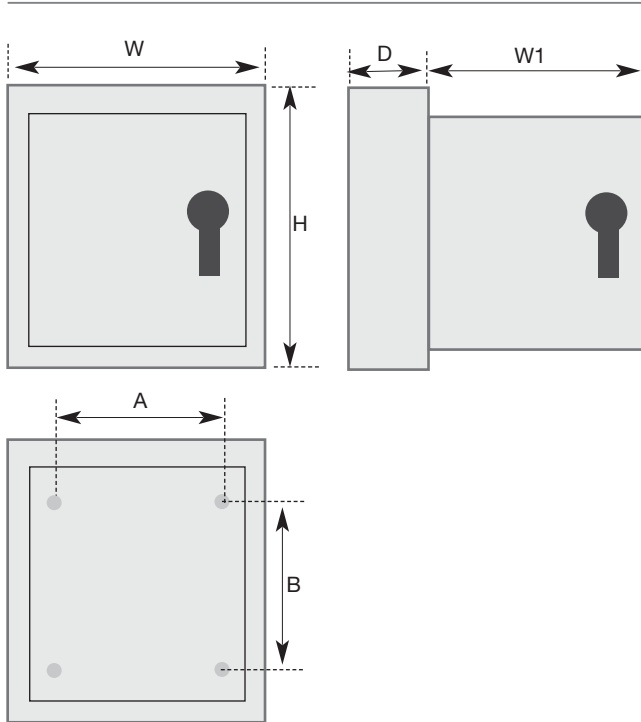

Reference						
	H	W	D	W1	A	B
JAB302	250	180	105	177	110	172
JAB402	250	180	105	177	110	172
JAB303	250	180	105	177	110	172
JAB403	250	180	105	177	110	172
JAB306	250	180	105	177	110	172
JAB406	250	180	105	177	110	172

JAB310	250	200	150	182	130	172
JAB410	250	200	150	182	130	172
JAC312	300	250	150	232	140	192
JAC412	300	250	150	232	140	192
JAC316	300	250	150	232	140	192
JAC416	300	250	150	232	140	192

JAE320	400	375	200	357	265	292
JAE420	400	375	200	357	265	292
JAE325	400	375	200	357	265	292
JAE425	400	375	200	357	265	292

JAG331	500	375	200	357	265	380
JAG431	500	375	200	357	265	380
JAG340	500	375	200	357	265	380
JAG440	500	375	200	357	265	380

JAH363	650	500	300	481.5	390	529
JAH463	650	500	300	481.5	390	529
JAH380	650	500	300	481.5	390	529
JAH480	650	500	300	481.5	390	529
JAH390	1058	750	300	732	390	937
JAH490	1058	750	300	732	130	937

JZA700	200	250	300	/	140	100
JZA701	200	375	300	/	265	100
JZA702	200	500	300	/	390	134
JZA703	200	600	300	/	490	134

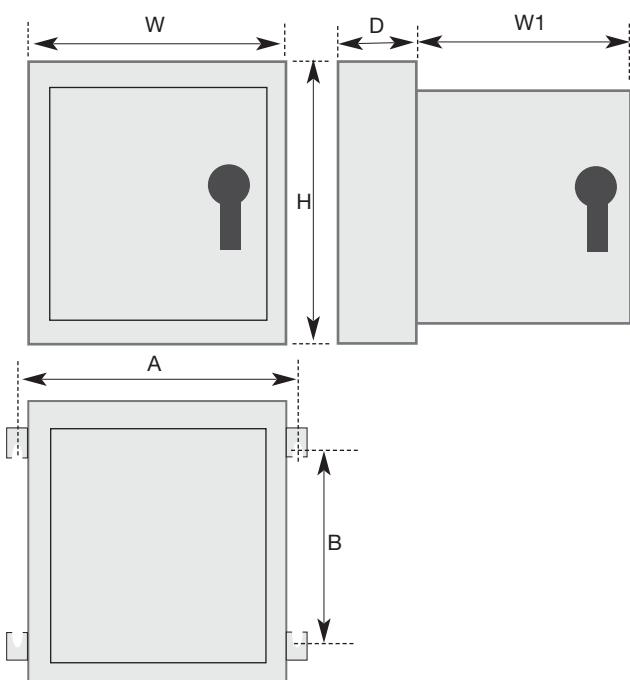

Reference							
		H	W	D	W1	A	B
JAB306S-IP55	JAB406S-IP55	300	300	200	300	330	195
JAB310S-IP55	JAB410S-IP55	300	300	200	300	330	195
JAC310S-IP55	JAC410S-IP55	400	300	200	300	330	295
JAE316S-IP55	JAE416S-IP55	600	400	250	400	430	495
JAE325S-IP55	JAE425S-IP55	600	400	250	400	430	495
JAG331S-IP55	JAG431S-IP55	700	500	250	500	530	595
JAG340S-IP55	JAG440S-IP55	700	500	250	500	530	595
JAH363S-IP55	JAH463S-IP55	800	600	400	600	630	695

Description

The range of IP66 isolators are designed to be used in outdoor applications with IP66 degree of protection. They are rated at AC22A and AC23A offer options of 2,3 poles and 4 poles with switched neutral. They are compact and easy to install with 2 screw quick release top cover

Rated voltage: 250 V AC
440 V AC
Material: Polycarbonate-UV grade

Rating AC22A is for switching of mixed resistive and inductive loads, including moderate overloads.

Rating AC22A is for switching of mixed resistive and inductive loads, including moderate overloads.

Rating AC23A is for switching of motor loads or other highly inductive loads.

Mechanical specification:

Protection category: IP66

Devices & accessories:

DP 20-40A
TP & N 20-40A
TP & SW N 20-63A

Complies with

BS EN 60947-3
IEC 60947-3
AS 3947-3

Designation	Characteristics	Pack qty.	Cat.Ref
-------------	-----------------	-----------	---------



JG220U

Rating: AC22A

2 pole

20A	2 pole IP66	1	JG220U
32A	2 pole IP66	1	JG232U
40A	2 pole IP66	1	JG240U
63A	2 pole IP66	1	JG263U

3 pole

20A	3 pole IP66	1	JG320U
32A	3 pole IP66	1	JG332U
40A	3 pole IP66	1	JG340U

3 pole + switched neutral

20A	4 pole IP66	1	JG420U
32A	4 pole IP66	1	JG432U
40A	4 pole IP66	1	JG440U
63A	4 pole IP66	1	JG463U



JG320IN

Rating: AC23A

2 pole

20A	2 pole IP66	1	JG220IN
32A	2 pole IP66	1	JG232IN
40A	2 pole IP66	1	JG240IN
63A	2 pole IP66	1	JG263IN

3 pole

20A	3 pole IP66	1	JG320IN
32A	3 pole IP66	1	JG332IN
40A	3 pole IP66	1	JG340IN

3 pole + switched neutral

20A	4 pole IP66	1	JG420IN
32A	4 pole IP66	1	JG432IN
40A	4 pole IP66	1	JG440IN
63A	4 pole IP66	1	JG463IN



JG380S

Rating: AC22A

3 pole

63A	3P IP65 isolator	1	JG363S
80A	3P IP65 isolator	1	JG380S
125A	3P IP65 isolator	1	JG325S

**2 pole**

Reference	Current	H	W	D
JG220U	20A	170	84	87
JG232U	32A	170	84	87
JG240U	40A	170	84	87
JG263U	63A	170	84	87

• All dimensions are in mm

3 pole

Reference	Current	H	W	D
JG320U	20A	170	84	87
JG332U	32A	170	84	87
JG340U	40A	170	84	87

• All dimensions are in mm

3 pole + switched neutral

Reference	Current	H	W	D
JG420U	20A	170	84	87
JG432U	32A	170	84	87
JG440U	40A	170	84	87
JG463U	63A	170	84	87

• All dimensions are in mm

2 pole

Reference	Current	H	W	D
JG220IN	20A	170	84	87
JG232IN	32A	170	84	87
JG240IN	40A	170	84	87
JG263IN	63A	170	84	87

• All dimensions are in mm

3 pole

Reference	Current	H	W	D
JG320IN	20A	170	84	87
JG332IN	32A	170	84	87
JG340IN	40A	170	84	87

• All dimensions are in mm

3 pole + switched neutral

Reference	Current	H	W	D
JG420IN	20A	170	84	87
JG432IN	32A	170	84	87
JG440IN	40A	170	84	87
JG463IN	63A	170	84	87

• All dimensions are in mm

Energy & lighting control

comfort and efficiency

Energy and lighting control product range allows to optimise energy consumption while increasing comfort



Latching relays	38
<hr/>	
Latching relays auxiliaries	39
<hr/>	
Relays & interface relays	42
<hr/>	
Contactors	43
<hr/>	
Override contactors	45
<hr/>	
Auxiliaries for contactors and relays	46

Description

For the control of lighting circuits in residential buildings, small industry buildings and commercial buildings. Latching relays operates when impulsed by a signal voltage. The impulse can be provided via a pushbutton or switch. The first impulse sets the relay into its set (opposite) state, the next impulse returns it to its reset (original) state.

The latching relays are built to add on optionally the following auxiliaries :









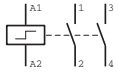

- an auxiliary for centralised ON/OFF control EPN 050
- an auxiliary contact for remote signalling EPN 051
- an auxiliary for multi levelled centralised control EPN 052
- an auxiliary for control by maintained contact EPN 053

Connection capacity

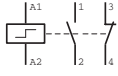
10mm² rigid cables
6mm² flexible cables

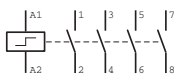
Conform to standard

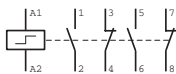
IEC60669-1 and IEC60669-2-7

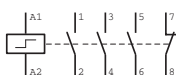
Designation	Type	Coil VAC 50Hz	Coil VDC	Power Circuit AC1	Width in 17.5mm	Pack qty.	Cat. Ref.
 EPN510		230	110	16A-250V	1	12	EPN510
		48	24	16A-250V	1	12	EPN501
		24	12	16A-250V	1	12	EPN513
		12	-	16A-250V	1	12	EPN511
		8	-	16A-250V	1	12	EPN512
 EPN520		230	110	16A-250V	1	1	EPN520
		110	48	16A-250V	1	1	EPN523
		48	24	16A-250V	1	1	EPN526
		24	12	16A-250V	1	1	EPN524
		12	-	16A-250V	1	1	EPN521
		8	-	16A-250V	1	1	EPN522
 EPN540		230	110	16A-250V	1	1	EPN515
		110	48	16A-250V	1	1	EPN516
		48	24	16A-250V	1	1	EPN503
		24	12	16A-250V	1	1	EPN518
		12	-	16A-250V	1	1	EPN519
 EPN540		230	110	16A-400V	2	1	EPN540
		48	24	16A-400V	2	1	EPN548
		24	12	16A-400V	2	1	EPN541
 EPN540		230	110	16A-250V	2	1	EPN525
		24	12	16A-250V	2	1	EPN528
 EPN540		230	110	16A-400V	2	1	EPN546

Auxiliaries for centralised control
 The EPN 050 allows the centralised control of several light sources which can be turned on or off simultaneously. The separate switching by pushing the pushbuttons, which are connected with the latching relay, remains possible.

The EPN 052 allows an overall central control of individual central on/off EPN 050

Auxiliary contact
 A remote signalling can be realised with the auxiliary contact EPN 051.

Auxiliary for control by maintained contact
 When control devices with permanent impulse are externally driven, e.g. time switches or limit switches, an impulse control directly to the latching relay's coil is possible with the auxiliary contact EPN 053.

Connection latching relay + auxiliary
 Several auxiliaries can be combined with the latching relay.

Connection capacity
 10mm² rigid cables
 6mm² flexible cables

Designation	Voltage supply	Width in ■ 17.5mm	Pack qty.	Cat. Ref.
-------------	----------------	----------------------	--------------	-----------



EPN050

Auxiliary for centralised control

24 to 230V AC

1/2

1

EPN050

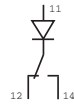

EPN051

Auxiliary contact

2A 250 V AC

1/2

1

EPN051



EPN052

Auxiliary for multi levelled centralised control

24 to 230V AC

1/2

1

EPN052



EPN053

Auxiliary for control by maintained contact

24 to 230V AC
 12 to 110V DC

1/2

1

EPN053



Technical characteristics

	EPN510 EPN515 EPN520	EPN516 EPN523	EPN501 EPN503 EPN526	EPN513 EPN518 EPN524	EPN511 EPN519 EPN521	EPN512 EPN522	EPN525 EPN540 EPN546	EPN548	EPN528 EPN541
Coil in AC									
voltage rating	230V	110V	48V	24V	12V	8V	230V	48V	24V
tolerance	+10/-20%								
frequency	50Hz								
start consumption	25VA						55VA		
Coil in DC									
voltage rating	110V	48V	24V	12V	-	-	110V	24V	12V
tolerance	+10/-20%								
start consumption	12VA						25VA		
Contacts									
max. perm. Current AC1	16A								
voltage	250V AC						400V AC		
electrical endurance	150 000 operations								
mechanical endurance	500 000 operations								
ohmic loss per current path	1.2W								
minimum duration of impulse	50 ms								
maximum time under voltage	1 H								
pushbutton with signal lamp									
without condensator	6 (1mA / lamp)								
ingress protection	IP20								
working temperature	-5 to +40°C								
storage temperature	-40 to +80°C								
Connection									
flexible	6 mm ²								
rigid	10 mm ²								

* condensator parrallel with the coil

Incandescent lamps 230V with and without halogen	load	40W	60W	75W	100W	150W	200W	300W	500W
	number	45	30	24	15	12	9	5	3
Incandescent lamps Low voltage halogen	load	20W	50W	75W	100W	150W	300W		
	number	70	28	19	14	9	3		
Fluorescent lamps Uncompensated	load	15W	18W	30W	36W	58W			
	number	29	25	25	24	14			
Fluorescent lamps Parrallel compensation	load	15W	18W	30W	36W	58W			
	number	27	27	25	25	16			
	C total max _(a)	121µF	121µF	112µF	112µF	112µF			
Two lamps circuit series compensation	load	2x18W	2x20W	2x36W	2x40W	2x58W	2x65W		
	number	40	40	22	22	12	12		
	C	2.7µF	2.7µF	3.4µF	3.4µF	5.3µF	5.3µF		
	load	18W	36W	58W					
Two lamp circuit with electronics power supply units	number	30	28	15					
	load	2x18W	2x36W	2x58W					
Fluo compact uncompensated	number	15	13	8					
	load	7W	10W	18W	26W				
Fluo compact electronic power supply unit	number	50	45	40	25				
	load	11W	15W	20W	23W				
High intensity discharge metal halogen lamps, uncompensated	number	80	60	50	40				
	load								
Metal halogen lamps, parrallel compensation	load	50W	80W	125W	250W	400W			
	number	11	9	7	3	2			
	C total max _(a)	9	8	6	3	2			
High pressure sodium vapour lamps, uncompensated	load	63µF	58µF	60µF	54µF	50µF			
	number	70W	150W	250W	400W				
High pressure sodium vapour lamps, parrallel compensated	number	9	5	3	2				
	load	70W	150W	250W	400W				
	C total max _(a)	5	3	2	1				
	load	60µF	54µF	64µF	50µF				

(a): these values must not be exceeded

Auxiliaries for latching relays

	EPN050	EPN051	EPN052 - EPN053
voltage rating	(a)	-	(a)
	24 to 230V AC	-	24 to 230V AC
nominal load	-	2A/250V AC	-
I _{min} /230V AC	-	15mA	-
working temperature	-5 to +40°C		
storage temperature	-40 to 80°C		
Connections : flexible	6 mm ²		
rigid	10mm ²		

(a) : according to a latching relay connected with an auxiliary

Installation of the auxiliaries

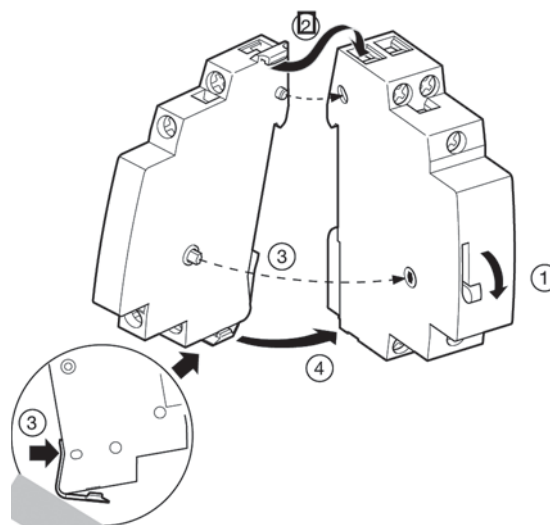

Application diagram

centralised command (EPN 050 - EPN 052)

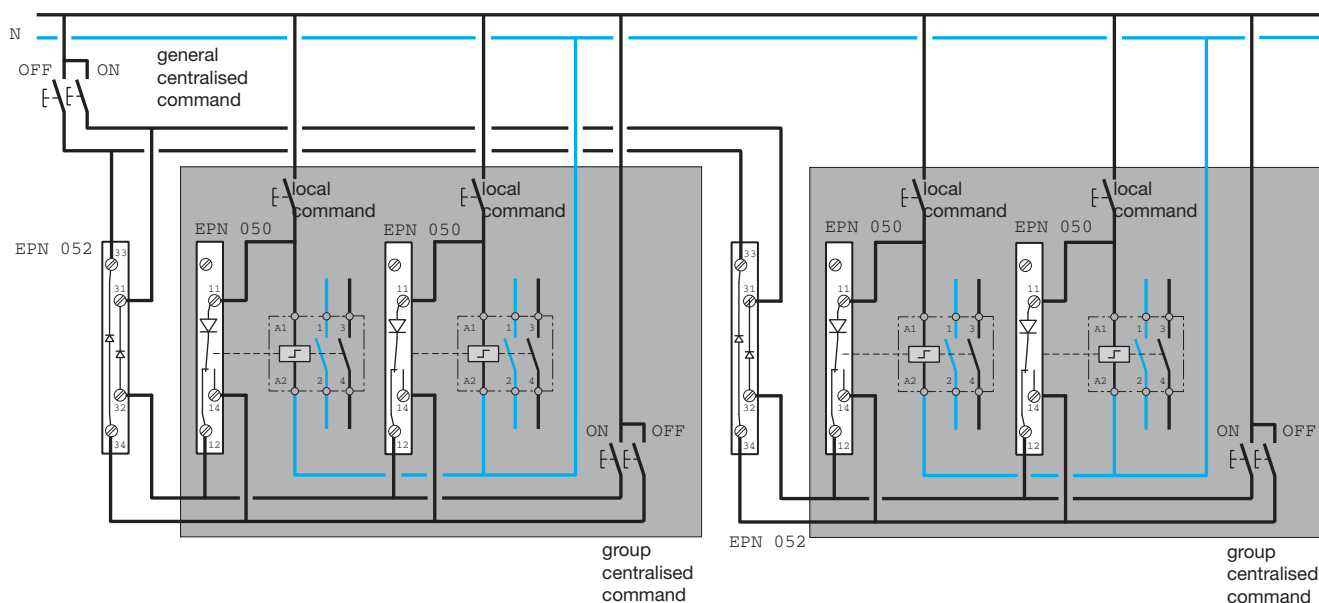

Remote signalling (EPN 051)

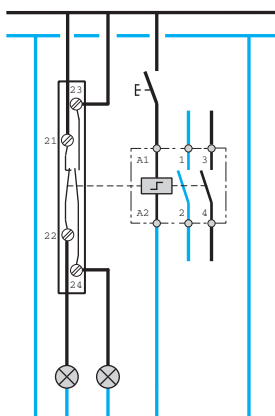

Maintained command (EPN 053)

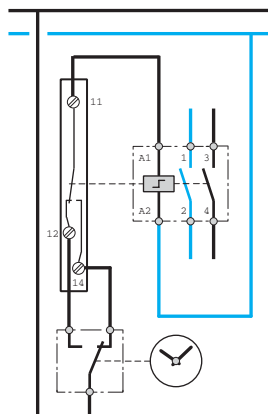

Relays

To provide remote control of low power circuits max.16A.

They are equipped with a 3 position manual control button:

- permanent ON,
- automatic mode,
- permanent OFF.

Complies with IEC 61095.

It is recommended to use a heat

dissipation insert LZ060 between each 3 products.

Auxiliary contact

Associated with a relay, it allows remote signaling.

Mechanical status indicator

Interface relays

Power contacts adapted to very low voltage circuits. It is operating silently.

A signal indicates when the coil

is under voltage.

These relays ensure a galvanic isolation between LV and VLV up to 4kV.

Description	Type	Coil AC 50Hz	In power circuit AC7-a / AC1	Width in 17.5mm	Pack qty.	Cat. ref.
-------------	------	--------------	------------------------------	-----------------	-----------	-----------

Relays

	2NO	230V	16A-250V	1	1	ERC216
		24V	16A-250V	1	1	ERD216
		8/12V	16A-250V	1	1	ERL216
	2NC	230V	16A-250V	1	1	ERC217
		24V	16A-250V	1	1	ERD217
		8/12V	16A-250V	1	1	ERL217
	1NO+1NC	230V	16A-250V	1	12	ERC218
		24V	16A-250V	1	1	ERD218
		8/12V	16A-250V	1	1	ERL218
	3NO	230V	16A-440V	2	1	ERC316
	4NO	230V	16A-440V	2	1	ERC416
	2NO+2NC	230V	16A-440V	2	1	ERC418
		24V	16A-440V	2	1	ERD418
		12V	16A-440V	2	1	ERL418

Humfree relays

	2NO+2NC	24V AC/DC	16A-440V	2	1	ERD418S
		12V AC/DC	16A-440V	2	1	ERL418S

Interface relays VLV/LV

	coil voltage: 10 to 26V AC/DC output: 1 changeover contact max. 5A 230V AC min. 10mA - 12V DC	1	1	EN145
--	---	---	---	--------------

Interface relays LV/VLV

	coil voltage: 230V AC output: 1 changeover contact max. 5A 230V AC min. 10mA - 12V DC	1	1	EN146
--	---	---	---	--------------



ERC218



ERC418



EN145

Contactors

Contactors are essential power devices to control heating, lighting or ventilation systems. They are recommended in association with control and energy management devices (thermostats, delay timers, programmers...)





Standard 1 and 2 versions are recommended for applications where a reduced consumption

and heating dissipation are needed.

Complies with IEC 61095.

The contactors can be associated with the auxiliary contact ESC080 for remote signaling.

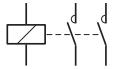
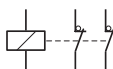
It is recommended to use a heat dissipation insert LZ060 between each 3 products.

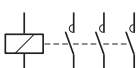
Description	Type	Coil AC 50Hz	In power circuit AC7-a / AC1	Width in 17.5mm	Pack qty.	Cat. ref.	
Contactors							
	1NO	230V	25A-250V	1	12	ESC125	
		24V	25A-250V	1	1	ESD125	
		8/12V	25A-250V	1	1	ESL125	
	1NC	230V	25A-250V	1	1	ESC126	
		<hr/>					
	2NO	230V	25A-250V	1	12	ESC225	
			40A-440V	3	1	ESC240	
			63A-440V	3	1	ESC263	
		24V	25A-250V	1	12	ESD225	
			40A-440V	3	1	ESD240	
			63A-440V	3	1	ESD263	
		12V	40A-440V	3	1	ESL240	
			63A-440V	3	1	ESL263	
			8/12V	25A-250V	1	1	ESL225
			110/127V	25A-250V	1	1	ESM225
	2NC	230V	25A-250V	1	12	ESC226	
			40A-440V	3	1	ESC241	
			63A-440V	3	1	ESC264	
		24V	25A-250V	1	1	ESD226	
			40A-440V	3	1	ESD241	
			63A-440V	3	1	ESD264	
		12V	40A-440V	3	1	ESL241	
			63A-440V	3	1	ESL264	
			8/12V	25A-250V	1	1	ESL226
			<hr/>				
	1NO+1NC	230V	25A-250V	1	12	ESC227	
		24V	25A-250V	1	1	ESD227	
		8/12V	25A-250V	1	1	ESL227	
		110/127V	25A-250V	1	1	ESM227	
	3NO	230V	25A-440V	2	6	ESC325	
			40A-440V	3	4	ESC340	
			63A-440V	3	1	ESC363	



ESC225



ESD263



ESC325



ESC425



ESC463

Description	Type	Coil AC 50Hz	In power circuit AC7-a / AC1	Width in ■ 17.5mm	Pack qty.	Cat. ref.	
Contactors							
	4NO	230V	25A-440V	2	6	ESC425	
			40A-440V	3	4	ESC440	
			63A-440V	3	4	ESC463	
		24V	25A-440V	2	6	ESD425	
			40A-440V	3	1	ESD440	
			63A-440V	3	1	ESD463	
		12V	25A-440V	2	1	ESL425	
			40A-440V	3	1	ESL440	
			63A-440V	3	1	ESL463	
			110/127V	40A-440V	3	1	ESM440
		4NC	230V	25A-440V	2	1	ESC426
				40A-440V	3	1	ESC441
63A-440V				3	1	ESC464	
		24V	25A-440V	2	1	ESD426	
			63A-440V	3	1	ESD464	
			12V	25A-440V	2	1	ESL426
		2NO+2NC	230V	25A-440V	2	1	ESC427
				40A-440V	3	1	ESC442
				63A-440V	3	1	ESC465
		24V	25A-440V	2	1	ESD427	
			12V	25A-440V	2	1	ESL427
				3NO+1NC	230V	25A-440V	2
40A-440V	3	4				ESC443	
63A-440V	3	1				ESC466	
	24V	25A-440V		2	1	ESD428	
		12V		25A-440V	2	1	ESL428

Override contactors

For the remote switching and control of power circuits.

They are equipped with a 3 position manual control button:

- permanent ON,
- automatic mode,
- permanent OFF.

Can be associated with the auxiliary contact ESC080 for remote signaling.

Complies with IEC 61095.

It is recommended to use a heat dissipation insert LZ060 between each 3 products.



ERC225



ERC425

Description	Type	Coil AC 50Hz	In power circuit AC7-a / AC1	Width in 17.5mm	Pack qty.	Cat. ref.	
Override contactors							
	1NO	230V	25A-250V	1	12	ERC125	
	2NO	230V	25A-250V	1	12	ERC225	
			40A-440V	3	1	ERC240	
			63A-440V	3	1	ERC263	
		24V	25A-250V	1	12	ERD225	
			40A-440V	3	1	ERD240	
			63A-440V	3	1	ERD263	
		12V	25A-250V	3	1	ERL225	
			40A-440V	3	1	ERL240	
			63A-440V	3	1	ERL263	
	8/12V	25A-250V	1	1	ERL225		
	2NC	230V	25A-250V	1	12	ERC226	
	3NO	230V	25A-440V	2	6	ERC325	
		4NO	230V	25A-440V	2	6	ERC425
			24V	25A-440V	2	6	ERD425
12V	25A-440V		2	1	ERL425		
	4NC	230V	25A-440V	2	1	ERC426	
	2NO+2NC	230V	25A-440V	2	1	ERC427	
	3NO+1NC	230V	25A-440V	2	1	ERC428	

Auxiliary contact

Associated with a relay or a contactor, it allows to show the product status or remote signaling.

Not compatible with 1 module humfree contactors and EN145 / EN146.

Heat dissipation insert

It is recommended to use a heat dissipation insert LZ060 between each 3 products.

Sealing covers

Not compatible with EN145 / EN146.

Description	Type	In power circuit AC7-a / AC1	Width in ■ 17.5mm	Pack qty.	Cat. ref.
-------------	------	---------------------------------	----------------------	--------------	-----------

Auxiliary contact



1NO+1NC

6A-250V

1/2

1

ESC080



ESC080

Sealing cover

for **1■** contactors

1

10

ESC001

for **2■** contactors

2

10

ESC002

for **3■** contactors

3

10

ESC003



ESC002

Heat dissipation insert

1/2

12

LZ060



LZ060

Description		Modular contactor and relay						Auxiliary contact
Standard conformity		EN 61095						
Approvals		NF - VDE - IMQ - KEMA - RMC / CCC						
		Relay	Contactor	Relay	Contactor	Contactor	Contactor	Accessory
Number of modules		1		2		3		0.5
Thermal current I _{th} (40°C)		16A	25A	16A	25A	40A	63A	6A
Rated frequency		50Hz	50Hz	50Hz	50Hz	50Hz	50Hz	50Hz
Rated insulation voltage (U _i)		250V	250V	440V	440V	440V	440V	250V
Rated impulse withstand voltage (U _{imp})		4kV	4kV	4kV	4kV	4kV	4kV	4kV
Protection degree		2	2	2	2	2	2	2
Rated operating currents and power ratings in AC								
AC-1 / AC-7a	rated operational currents I _e	16A	25A	16A	25A	40A	63A	-
	rated operational power	230V 400V	3kW -	4.6kW -	3kW 8.9kW	4.6kW 13.8kW	7.3kW 22kW	11.6kW 35kW
AC-3 / AC-7b	rated operational currents I _e	5.5A	8.5A	5.5A	8.5A	25A	32A	-
	rated operational power	230V 400V	570W -	880W -	570W 1.7kW	880W 2.6kW	2.6W 7.8kW	3.3W 10kW
AC-12	rated operational currents at 230V	-	-	-	-	-	-	6A
AC-15	rated operational currents at 230V	-	-	-	-	-	-	2A
Mechanical and electrical endurance								
Mechanical endurance	nr of operations	1,000,000	1,000,000	1,000,000	1,000,000	1,000,000	1,000,000	1,000,000
Electrical endurance at I _e AC7a (AC12 for aux contacts)	nr of operations	60,000	60,000	60,000	60,000	60,000	60,000	60,000
MCB protected short-circuit withstand								
Prospected short-circuit current	rms	1kA	3kA	1kA	3kA	3kA	3kA	1kA
Associated protection		MCB C16-6kA	MCB C25-6kA	MCB C16-6kA	MCB C25-6kA	MCB C40-10kA	MCB C63-10kA	6A 10x38 gG fuse or mcb
Power dissipation								
Power dissipation per current path		1W	1.5W	1W	1.5W	3.2W	5W	0.4W
Magnetic system for eco and standard contactor								
Pick-up		7.4VA	7.4VA	9.2VA	9.2VA	60VA	60VA	-
Coil consumption		1.8VA	1.8VA	1.85VA	1.85VA	7VA	7VA	-
Closing delay		25ms	25ms	25ms	25ms	25ms	25ms	-
Opening delay		15ms	15ms	15ms	15ms	20ms	20ms	-
Connection								
Main contact cable section	rigid	1...10mm ²	1...10mm ²	1...10mm ²	1...10mm ²	4...25mm ²	4...25mm ²	1...6mm ²
	flexible	1...6mm ²	1...6mm ²	1...6mm ²	1...6mm ²	4...16mm ²	4...16mm ²	1...6mm ²
Main contact connection screw	type	M3.4	M3.4	M3.4	M3.4	M5	M5	M3.4
	posidrive	PZ2	PZ2	PZ2	PZ2	PZ2	PZ2	PZ2
	max. tight. torque	1.2Nm	1.2Nm	1.2Nm	1.2Nm	2Nm	2Nm	1.2Nm
Coil connection cable section	rigid	1...10mm ²	1...10mm ²	1...10mm ²	1...10mm ²	1...10mm ²	1...10mm ²	-
	flexible	1...6mm ²	1...6mm ²	1...6mm ²	1...6mm ²	1...6mm ²	1...6mm ²	-
Coil connection screw	type	M3.5	M3.5	M3.5	M3.5	M4	M4	-
	posidrive	PZ2	PZ2	PZ2	PZ2	PZ2	PZ2	-
	max. tight. torque	1.2Nm	1.2Nm	1.2Nm	1.2Nm	1.5Nm	1.5Nm	-
Working temperature								
		-10°C to +50°C						
Storage temperature								
		-40°C to +80°C						

Choice of contactors

The choice of contactor is based on many factors:

- type of the load supplied,
- nominal current of the load,
- operating voltage,
- number of operations, etc..

The contactors are AC7-a (resistive load) and AC7-b (inductive load) approved.

Heating applications

The choice of the contactor is based on the electrical heating load, and the targeted life time.

Single phase

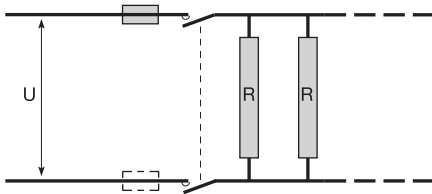

Three phase supply

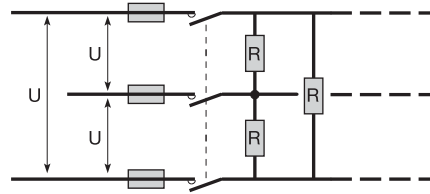

Number of operations			60,000	100,000	150,000	300,000	600,000
Maximum load* in kW	230V	16A	3.0	2.5	1.9	0.8	0.7
		25A	4.6	4.0	3.0	1.3	1.0
		40A	7.3	6.3	4.7	2.2	1.6
		63A	11.6	10.0	7.5	3.5	2.5
	400V	16A	8.9	8.0	5.8	2.8	2.0
		25A	13.8	12.0	8.6	4.3	3.0
		40A	22.0	18.5	14.3	6.3	5.0
		63A	35.0	30.0	22.6	10.2	7.6

* On three phase configuration the maximum load per phase corresponds to the values states divided by 3.

Example:

Function of a heating installation 200 days/annum, 75 operations

per day (1 opening + 1 closing = 2 operations)

Mechanical life = 10 years

Total number of operations: $200 \times 75 \times 10 = 150,000$

in that case, depending on the type of circuit, select a contactor 40A 230V to control a load of 4.7 kW, or a contactor 16A 400V to control a load up to 5.8 kW.

**Motor applications (AC7-b equivalent to AC3)
Single phase 230V**

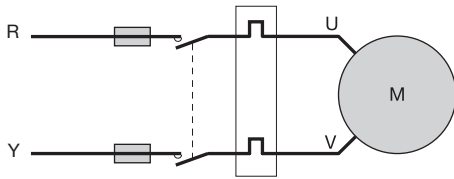

Three phase 400V

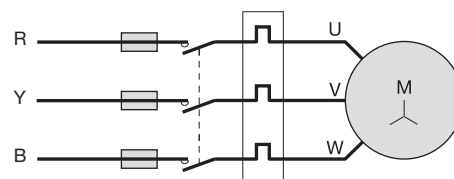

	Contactor rating	Control diagram	
		2P 230V single phase	3P 400V three phase
Maximum power for the motor	16A	0.57 kW	1.7 kW
	25A	0.88 kW	2.65 kW
	40A	2.6 kW	7.8 kW
	63A	3.3 kW	10 kW

Influence of working temperature:

Derating factor between 40°C and 50°C : 0.9

Example: heating with convector

The maximum load of ESC225 is 4.6kW for 60,000 operations and for a temperature <40°C.

between 40°C and 50°C, the load is 4.6 x 0.9 i.e. 4.14kW

Adjacent fitting:

It is necessary to put a heat dissipation insert (reference LZ060) between each 3 products, or each humfree contact.

Lighting selection

Due to the large variety of electrical characteristics in lamps, especially for the inrush current, the chart gives the maximum number of lamps based on the lamp technology and the inrush current (high / low). The goal is to give the most precise and the highest number of lamps acceptable for the contactor.

If the inrush current is not known, choose the column "I peak high" in order to favour the contactor lifetime.

The table below indicates the number of lamps (or dual fittings) that can be connected to each pole of the contactor on 230V/50hz circuits.

Type	Power	1 and 2 modules				3 modules			
		I peak high 16A	I peak low 16A	I peak high 25A	I peak low 25A	I peak high 40A	I peak low 40A	I peak high 63A	I peak low 63A
Incandescent lamps									
tungsten & halogen lamps	40W	32	38	50	60	76	102	120	160
	60W	21	31	33	48	67	79	105	125
	75W	17	24	27	38	67	63	105	100
	100W	13	19	20	30	41	48	65	75
	150W	9	13	13	20	29	32	45	50
	200W	6	10	10	15	22	24	35	38
	300W	4	6	7	10	15	16	23	25
	500W	3	4	4	6	9	10	14	15
	1000W	1	2	2	3	4	5	7	8
	Fluorescent tubes								
energy saving lamp compact fluo lamp with external electronic ballast or compensated	13W	11	21	17	33	55	108	86	170
	14W	7	21	11	33	36	108	57	170
	17W	7	21	11	33	36	108	57	170
	18W	7	21	11	33	36	108	57	170
	24W	7	17	11	27	36	75	57	91
	26W	7	12	11	19	36	58	57	91
	32W	7	12	11	19	36	58	57	91
	36W	7	12	11	19	36	58	57	91
	40W	7	12	11	19	36	58	57	91
	42W	7	12	11	19	36	58	57	91
	55W	7	12	11	19	36	58	57	91
	60W	6	10	10	15	27	42	42	66
	energy saving lamp compact fluo lamp with integrated electronic ballast substitute for incandescent lamps	5W	17	32	27	50	86	159	135
7W		17	32	27	50	86	159	135	250
9W		17	32	27	50	86	159	135	250
11W		17	32	27	50	86	159	135	250
15W		17	32	27	50	86	159	135	250
18W		13	22	20	35	63	111	100	175
20W		13	22	20	35	63	111	100	175
23W		13	22	20	35	63	111	100	175
26W		13	22	20	35	63	111	100	175
single - electronic ballast or compensated	14W	7	32	11	50	36	162	57	255
	21W	7	21	11	33	36	108	57	170
	22W	7	21	11	33	36	108	57	170
	24W	7	17	11	27	36	81	57	127
	28W	7	17	11	27	34	81	53	127
	35W	7	17	11	27	34	81	53	127
	39W	7	12	11	19	29	58	45	91
	40W	7	12	11	19	29	58	45	91
	49W	6	12	10	19	29	58	45	91
	54W	6	12	10	19	29	58	45	91
	55W	6	10	10	15	27	44	42	70
	60W	6	10	10	15	27	44	42	70
	80W	6	10	10	15	27	44	42	70
	95W	6	7	10	11	25	29	39	46
	120W	6	7	10	11	25	29	39	46
double - electronic ballast	2x14W	7	17	11	27	34	81	53	127
	2x21W	7	12	11	19	29	58	45	91
	2x28W	6	10	10	15	27	44	42	70
	2x40W	6	10	10	15	27	44	42	70
	2x49W	6	7	10	11	25	29	39	46
	2x60W	6	7	10	11	25	29	39	46

Type	Power	1 and 2 modules				3 modules			
		I peak high 16A	I peak low 16A	I peak high 25A	I peak low 25A	I peak high 40A	I peak low 40A	I peak high 63A	I peak low 63A
Discharge lamps									
Low pressure sodium-vapour lamps (uncompensated)	18W	8	12	10	18	18	23	21	36
	35W	4	6	6	10	10	16	13	25
	55W	3	6	6	9	9	14	12	22
	90W	2	4	4	6	6	13	9	20
	135W	1	3	3	4	4	8	6	12
	180W	1	2	2	3	4	6	5	10
low pressure sodium-vapour lamps (electronic ballast)	35W	4	6	6	10	13	33	23	51
	55W	3	5	5	8	13	24	19	38
	66W	3	5	4	8	13	24	19	38
	91W	2	4	3	6	13	20	16	31
high pressure sodium-vapour lamps (uncompensated)	35W	11	17	14	22	30	40	35	60
	50W	9	15	12	17	22	28	25	42
	70W	8	10	9	12	18	20	19	32
	80W	7	9	8	11	15	19	18	29
	110W	6	8	7	10	14	17	16	25
	150W	4	6	5	7	10	13	12	18
	250W	2	3	3	4	6	8	7	11
	400W	0	0	0	1	4	5	5	8
	1000W	0	0	0	1	2	3	3	4
	high pressure sodium-vapour lamps (electronic ballast)	45W	6	10	9	12	13	36	25
50W		6	10	9	12	13	34	24	43
60W		6	10	9	12	13	32	23	41
70W		4	6	6	9	13	23	18	36
100W		3	6	5	9	13	18	16	32
150W		3	6	5	9	13	14	14	30
halogen metal vapour lamp (uncompensated)	35W	12	27	24	40	42	68	55	106
	70W	10	16	15	24	26	42	34	64
	150W	6	8	7	12	14	20	17	32
	250W	3	5	5	8	9	14	12	21
	400W	1	3	2	4	6	8	7	13
	1000W	0	0	0	1	3	4	4	5
halogen metal vapour lamp (electronic ballast)	20W	6	13	10	20	22	56	34	88
	35W	6	13	10	20	22	56	39	80
	70W	5	10	8	15	22	56	39	80
	150W	3	6	5	12	12	32	22	60
	210W	4	6	5	12	10	28	19	50
	315W	4	6	5	12	8	26	17	48

Power interface programming

solution for energy efficiency

Contactors, relays, delay timers, latching relays, energymeters: a whole range of devices to control installations for more energy efficiency.



Analogue time switches modular	54
<hr/>	
Analogue time switches 72 x 72mm	56
<hr/>	
Digital time switches	58
<hr/>	
Indicator lights	61
<hr/>	
Push buttons	62
<hr/>	
Twilight switches	64
<hr/>	
Multi-function meters	66

Description

Electromechanical time switches 1 channel for daily or weekly programming.
To control lighting, heating, household appliances, shop windows etc...
To improve comfort and save energy.

Applications

Domestic and commercial premises.
DIN rail mounting

Technical data

- programming by captive segments.
- manual override:
- On 1 module devices:
 - automatic
 - permanent ON
- On 3 and 5 module devices:
 - automatic
 - permanent ON
 - permanent OFF

Minimum switching time:

- 15 min for daily versions
- 2 hours for weekly versions
- 15 min and 2 hours on the daily+weekly version

Connection capacity:

1 to 4mm²

Complies with EN 60 730.

Designation	Voltage	Cycle	Width in ■ 17.5 mm	Cat. ref.
-------------	---------	-------	---	-----------



EH071

Analogue time switches modular compact	230V 50Hz	24h without battery reserve	1	EH010
1 NO 16 A - 250 V AC1		24h reserve: 200 h	1	EH011
		7day reserve: 200h	1	EH071

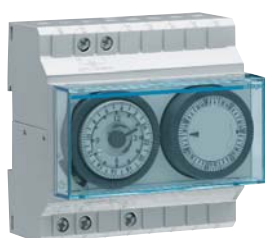

EH191

Analogue time switches standard modular version	230V 50Hz	24h without hand without battery reserve	2	EH209
1 NO changeover 16 A - 250 V AC1		24h without battery reserve	2	EH210
		24h reserve: 200 h	2	EH211
		7day reserve: 200 h	2	EH271
		24h + 7day reserve: 200h	5	EH191



EH111

		24h without battery reserve	3	EH110
		24h without battery reserve	3	EH111
	6 to 24V AC/DC	24h without battery reserve	3	EH110A
		24h reserve: 200 h	3	EH111A
		7day reserve: 200 h	3	EH171A



EH110A

Sealing kit for 3 "modules" time switch	EH901
--	--------------

Wall mounting kit for 3 "modules" time switch	EH902
--	--------------

Technical specifications

	EH010	EH011	EH071	EH110	EH111	EH191
Width in 17.5mm	1	1	1	3	3	5
Version	daily	daily	weekly			daily + weekly
Electrical characteristics						
voltage supply	230V +10/-10%			230V	230V	230V +10/-10%
frequency				50/60Hz		
consumption				0.5VA		
output	1NO			changeover		
Switching capacity						
AC1				16A/250V		
inductive load (cos φ = 0.6)	4A/250V			3A/250V		
incandescent lamps				900W		
Characteristics						
technology	quartz					
dial	24 h		7 days		24 h	24 h and 7 days
switching dial	15 min		1h 45			15 min and 2 h
min. switching	30 min		3 h 30		15 min	15 min and 2 h
max. number of switching	96		96			96/84
accuracy	+/- 1 sec per day					
supply failure reserve reached in		200 h	200 h			200 h
manual override	auto/ON/OFF					
Environment						
ingress protection	IP20					
working temperature	-10 to +45°C					
storage temperature	-10 to +50°C					
connection	0.5 to 4mm ²					

	EH209	EH210	EH211	EH271	EH110A	EH111A	EH171A
Width in 17.5mm	2	2	2	2	3	3	3
Version	daily	daily	daily	weekly	daily	daily	weekly
Electrical characteristics							
voltage supply	230V +10/-15%			230V +10/-15%		6 to 24V AC/DC	
frequency				50/60Hz		50/60 Hz	
consumption				0.5 VA		0.5 VA	
output	1NO changeover					1 NO changeover	
Switching capacity							
AC1				16A/230V		16A/230V	
inductive load (cos φ = 0.6)				4A/230V		4A/230V	
incandescent lamps				1000W		900W	
Characteristics							
technology	quartz				quartz		
dial	24 h			7 days	24 h		7 days
switching dial	15 min			1 h 45	15 min		2 h
min. switching	30 min			3 h 30	30 min		4 h
max. number of switching	48				48		
accuracy	+/- 1 sec per day				± 6 min per year		
supply failure reserve reached in	-	-	200 hours	200 hours	-	72 hours	72 hours
manual override	auto/ON/OFF				auto/ON/OFF		
Environment							
ingress protection	IP20				IP20		
working temperature	-10 to +55°C				-10° to +55°C		
storage temperature	-20° to +70°C				-20° to +70°C		-10° to +55°C
connection	1.5 to 6mm ²				1 to 4mm ²		

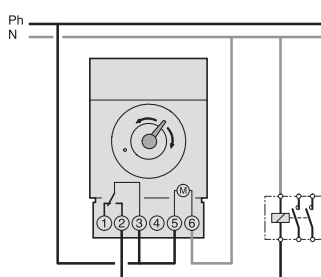

EH110 Electrical connections

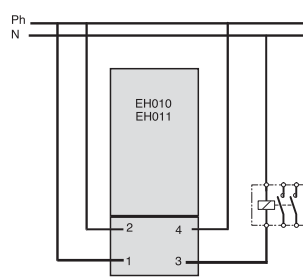

EH010, EH011 electrical connections

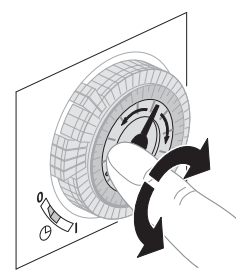
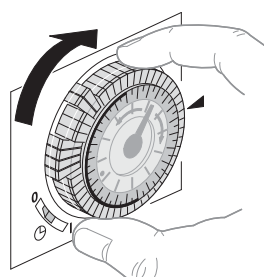

Simple time setting and programming using dual direction dial

Description

For daily or weekly programming.
1 channel for the control of lighting, heating, household appliances, shop windows etc..
To improve comfort and save energy.

Applications

Domestic and commercial premises.

Technical data

- suitable for surface, flush or din rail mounting
- programming by captive segments
- manual override with automatic return to programme
- operating reserve: 200 hours after being connected for 120 hours
- with clock hand
- output: voltage free changeover contact 16A/250V



Daily version

Programming in steps of 10 minutes.
Minimum time between 2 switching intervals: 20 min

Weekly version

Programming in steps of one hour.
- minimum time between 2 switching intervals: 2 hours
- switching accuracy: 10 min

Complies with EN 60 730-2-7.

Designation	Characteristics	Pack qty.	Cat. ref.
 <p>EH711</p>	1 channel daily cycle		
	supply : 230V 50/60Hz		
	without battery reserve	1	EH710
	with battery reserve	1	EH711
reserve : 200 hours after being connected for 120 hours			
 <p>EH771</p>	1 channel weekly cycle		
	supply : 230V 50/60Hz		
	without battery reserve	1	EH770
	with battery reserve	1	EH771
reserve : 200 hours after being connected for 120 hours			
1 channel daily cycle	supply : 6 to 24V AC/DC 50/60Hz		
without battery reserve		1	EH710A
Flush mounting kit			EH900

Technical specifications

	EH710	EH711	EH770	EH771	EH710A
Dimensions (mm)	72x72x48	72x72x48	72x72x48	72x72x48	72x72x48
Electrical characteristics	daily	daily	weekly	weekly	daily
voltage supply	230V +10/-15% 50/60Hz				110V to 240V AC 50/60Hz 48V DC +10/-15%
consumption	0.5VA				
output	1 changeover				1 N/O
Switching capacity					
AC1	16A/250V				
inductive load (cos φ = 0.6)	3A/250V				
incandescent lighting	1000W				
Characteristics					
technology	quartz				
dial	24h		7 days		24h
switching dial	10min		1 hour		10 min
minimum switching	20min		2 hour		20 min
working accuracy	+/- 1 sec per day				
supply failure reserve	-	200 hours	-	200 hours	-
reached in		120 hours		120 hours	
manual switch	temporary ON or OFF				
Environment					
working temperature	-10 to +50°C				
storage temperature	-20 to +60°C				
connection capacity	1 to 6mm ²				

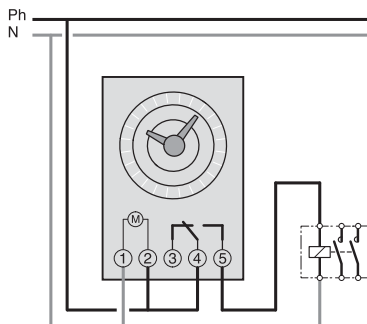

EH710 Electrical connection

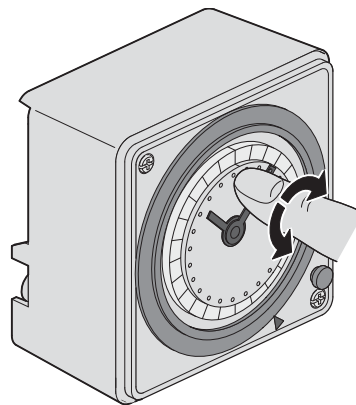

Very easy programming with dual direction dial

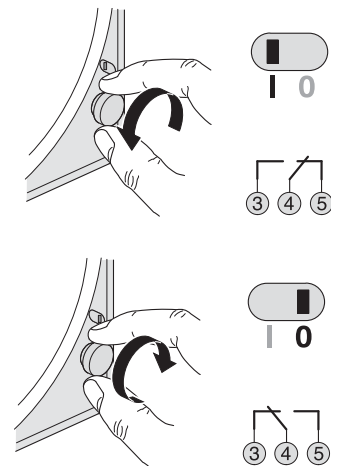

Manual override

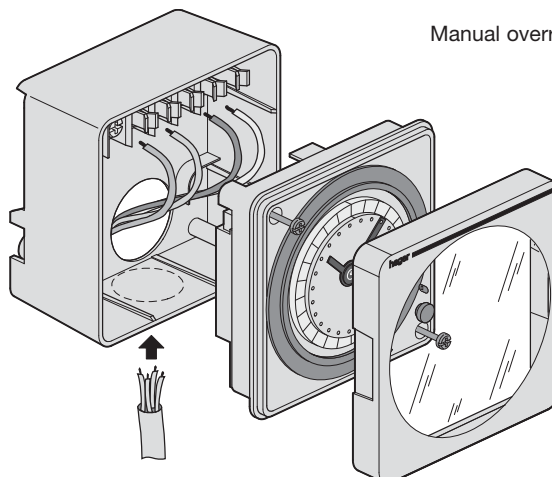
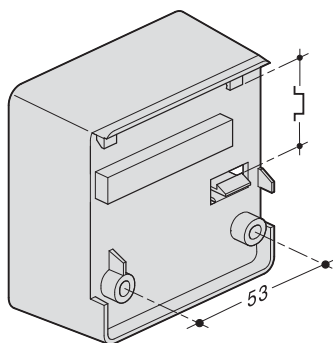

Description

Use : domestic and commercial buildings
 For the control of lighting, heating, household appliances, shop windows, signage etc..., to improve comfort and to save energy.

EG103B and EG203B

(basic version)
 Product set at current time and date when delivered.
 Automatic change of summer / winter time.

Programming key :

- to allow easy back up and re-installation of the program to allow permanent program overrides.
- programming per day or group of days
- 56 ON/OFF programme steps
- permanent ON/OFF overrides
- temporary ON/OFF overrides
- bar graph indication showing the daily profile
- programming supply.

Operating voltage

230V~ 50/60Hz

Designation	Characteristics	Width in 17.5mm	Pack qty.	Cat. ref.
1 channel daily cycle	5 adjustable pre-recorded programs : 6 commutations max per day (3 ON and 3 OFF) 230V 50/60 Hz	1	1	EG010
	capacity : 20 program steps 230V 50/60 Hz	3	1	EG110
2 channels daily cycle	capacity : 20 program steps to be divided between the 2 channels 230V 50/60 Hz	3	1	EG210
1 channel weekly cycle	capacity : 20 program steps 230V 50/60 Hz	1	1	EG071
	capacity : 20 program steps 230V 50/60 Hz	3	1	EG170
	capacity : 56 program steps output : 1 changeover contact μ 16A - 250V~ AC1	2	1	EG103B
	capacity : 56 program steps output : 1 changeover contact μ 16A - AC1 - 12/24 V AC/DC 50/60 Hz	2	1	EG103V
2 channels weekly cycle	capacity : 20 program steps to be divided between the 2 channels 230v 50/60 Hz	3	1	EG270
	capacity : 56 program steps output : 2 changeover contacts μ 16A - 250V~ AC1	2	1	EG203B



EG071



EG210



EG203E

Technical specifications

	EG010	EG110	EG210	EG071	EG170
Width in ■ 17.5mm	1	3	3	1	3
Version	daily	daily	daily	weekly	weekly
Electrical characteristics					
voltage supply	230V +15/-15% 50/60Hz		230V +15/-15% 50/60Hz	230V +15/-15% 50/60Hz	
consumption	1VA				
output	changeover contact				
Switching capacity					
AC1	16A/250V				
inductive load (cos φ = 0.6)	3A/250V				
incandescent lamps	1000W				
Characteristics					
accuracy	+/- 1 sec per day				
supply failure reserve	Lithium battery total of three years				
manual override	permanent ON/OFF	permanent ON/OFF temporary ON/OFF		permanent ON/OFF	permanent ON/OFF temporary ON/OFF
Environment					
ingress protection	IP20				
working temperature	-10 to +50°C				
storage temperature	-10 to +50°C				
connection	0.5 to 4mm ²				

	EG103B	EG203B
Width in ■ 17.5mm	2	2
Cycle	weekly	weekly
Channels	1	2
Program step	56	56
Min. switching time	1 min	
Electrical characteristics		
voltage supply	230V +15%/-15% 50/60Hz	
consumption	max 6VA	
output	changeover contact	
Switching capacity		
AC1	μ16A/250V	
inductive load (cos φ = 0.6)	μ10A/250V	
incandescent lamps	2300W	
halogen lighting 230V	2300W	
compensated fluo. tubes //	400W, C=45μF	
non compensated fluo. tubes	1000W	
compact fluorescent tubes	500W	
min. load switching	100mA/250V	
Characteristics		
accuracy	± 1,5 second per day	
supply failure reserve	lithium battery : 5 years	
manual override	permanent ON/OFF temporary ON/OFF	
Environment		
ingress protection	IP20	
working temperature	-5 to 45°C	
storage temperature	-20 to +70°C	
connection	flexible: 1 to 6mm ² rigid: 1.5 to 10mm ²	

Electrical connections

EG010

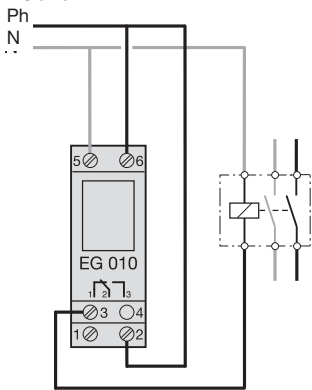

5 pre-registered programs:

P	Prog
P0	OFF
P1	ON
P2	6.00 — 23.00
P3	6.00 8.00 17.00 23.00
P4	6.00 8.00 11.00 13.00 17.00 23.00

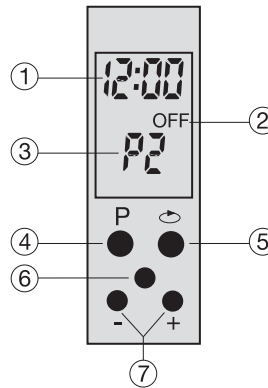

Display :

1. Time
2. Output contact (ON or OFF)
3. Program selected

Buttons :

4. To select the program to apply
5. To scroll program steps
6. Reset
7. + and - : change time settings

EG071

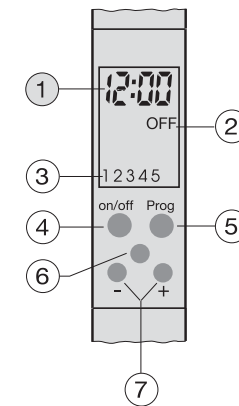
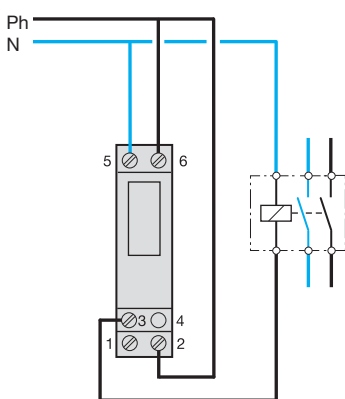

Display :

1. Time
2. Circuit status
3. Days

Buttons :

4. To select the program to apply
5. To scroll program steps
6. Reset
7. + and - : change time settings

	EG010	EG071
Electrical characteristics		
voltage supply	230V ±10% 50/60Hz	
consumption	1 VA	
output	1 changeover contact, 16A - 250V AC, 3A - 250V cos φ = 0,6, 1000W incandescent lighting	
Functional characteristics		
number of programs	5 adjustable pre-recorded programs	20 program steps (each program step can be applied to one of several days)
accuracy	± 6 min per year	
supply failure reserve	total of 3 years	
Environment		
working temperature	-10°C to +50°C	
storage temperature	-10°C to +60°C	
Cable capacity	1 to 4mm ²	
Main characteristics	5 programs are pre-recorded. The user just has to select the program which corresponds to its use and modify time switches if necessary	

EG170

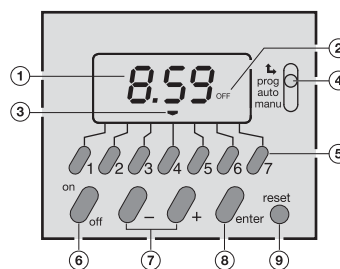
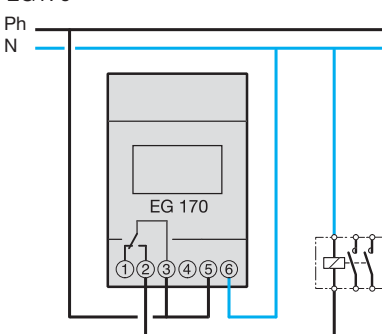

Display :

1. Time
2. Circuit status (ON or OFF)
3. Day of the week (1=Monday, 2= Tuesday,...)

Buttons :

4. Mode selector : to select one of the following modes :
 - time setting
 - programming
 - running mode
 - manual override
5. "1" to "7" : selection of the days
6. "ON/OFF" : chooses whether the circuits is ON or OFF.
7. "+" and "-" : changes settings
8. "enter" : to confirm selection
9. "reset"

Indicator lights and push buttons

These products are used for remote controlling signalisation of any event in any electric installation (domestic, tertiary & industrial)





LED technology providing longer life, new design, integrated label holder

Connection capacity :
- 10 mm² rigid,
- 6 mm² flexible

Comply with IEC 62094-1 (for indicator lights).



SVN122 SVN125 SVN121
SVN123 SVN124

Designation	Characteristics	Width in ■ 17.5mm	Pack qty.	Cat. Ref.
Single indicator light 230 V ~ 	LED light : green	1	12	SVN121
	red	1	12	SVN122
	orange	1	12	SVN123
	blue	1	12	SVN124
	clear	1	12	SVN125
Double indicator light 230 V ~ 	LED light: green and red	1	12	SVN126
	clear	1	12	SVN128
Triple indicator light 	LED light: red/red/red	1	12	SVN127
	red/orange/green	1	12	SVN129
	green/green/green	1	12	SVN221
	red/orange/blue	1	12	SVN222
Low voltage indicator lights 12 to 48 V AC/DC 	LED light: green	1	12	SVN131
	red	1	12	SVN132
	orange	1	12	SVN133
	blue	1	12	SVN134
	clear	1	12	SVN135
	green/red	1	12	SVN136

Push buttons





























2 versions :
 - impulse push buttons
 - latching push buttons

These versions with indicator lights are equipped with green or red diffuser. (led technology)

Connection capacity :

- 10 mm² rigid,
 - 6 mm² flexible.

Comply with IEC 60947-5-1 for push buttons and IEC 62094-1 for indicator lights

	Designation	Characteristics	Width in ■ 17.5mm	Pack qty.	Cat. Ref.
 SVN311	Impulse push buttons				
		16 A - 250 V AC without indicator light contact: 1NO	1	12	SVN311
		contact: 1NC	1	12	SVN321
		contacts: 2NO	1	12	SVN331
		contacts: 2NC	1	12	SVN341
		contacts: 1NO+1NC	1	12	SVN351
 SVN391		contacts: 2NO	1	12	SVN371
		contacts: 2NO + green push button	1	12	SVN373
		contacts: 1NO+1NC	1	12	SVN391
	with indicator light :				
		contact: 1NO green	1	12	SVN411
		contact: 1NC red	1	12	SVN422
 SVN411		contacts: 2NO red	1	12	SVN432
		contacts: 2NC green	1	12	SVN441
		contacts: 1NO+1NC red	1	12	SVN452
	16 A - 12/48 V AC/DC with indicator light				
		contacts: 2NO green	1	12	SVN461
		contacts: 2 NO red	1	12	SVN462
 SVN422	Latching push buttons				
		16 A - 250 V AC without indicator light contact: 1NO	1	12	SVN312
		contact: 1NC	1	12	SVN322
		contacts: 2NO	1	12	SVN332
		contacts: 2NC	1	12	SVN342
		contacts: 1NO+1NC	1	12	SVN352
 SVN422	with indicator light :				
		16 A - 250 V AC contact: 1 NO green	1	12	SVN413
		contacts: 2 NO green	1	12	SVN433
	16 A - 12/48 V AC				
		contacts: 2NO green	1	12	SVN463
		contacts: 2 NO red	1	12	SVN464

Electrical and mechanical characteristics

General features

Part number	SVN1... / SVN2...	SVN4...	SVN3...
Designation	indicator lights	indicator lights + push buttons indicator lights	push buttons
Standard	IEC62094-1		IEC60947-5-1
Light technology	LED light		
Electrical characteristics			
Rated insulation voltage	250V		
Rated impulse withstand voltage	4kV (2kV for 12-48V version)	4kV	
Operational voltage	230V AC (1)		
Frequency	50/60Hz		
Operational thermal current	n/a	16A	
Operational current @ 230V AC12	n/a	16A	
Operational current @230V AC14	n/a	10A	
LED power	0,8W (230V) 0,33W (48V) 0,08W (24V) 0,018W (12V)		
LED consumption	3,45mA (230V) 6,9mA (48V) 3,3mA (24V) 1,5mA (12V)	9,7mA (48VDC)4,6mA (24VDC) 2,1mA (12VDC)	
Conditional short circuit current	n/a	1000A with gl 10A fuse	
IP class	IP2X		
Degree of pollution	3		
Connecting			
Type of connection	cage terminals		
Connection capacity with flexible cable	0,75mm ² to 6mm ²		
Connction capacity with rigid cable	0,75m ² to 10m ²		
Terminal tightening torque	mini : 1,3Nm ; Max 2Nm : advised 1,65Nm rigid and 1,8Nm suppl		
Case material	Thermoplastic (Polyamide) comply with IEC 695-2-2		
Mechanical characteristics			
Electric endurance in number of cycles	n/a	15000 (AC12); 6000 (AC14)	
Mechanical endurance in no. of operations	n/a	15000	
Life time	100000 h		
Operating temperature	-20 to +50°C		
Storage temperature	-40 to +80°C		
Climat environment	all climates		
Protection index IP	20		
Height	2000 m		
Installation			
Mounting	DIN rail EN50.022-35		
Mounting position	performances not affected if installed vertically, horizontally or flat		

(1) except 12 to 48V indicator light (SVN131, SVN132, SVN133, SVN134, SVN135)

Description

The light sensitive switch controls light systems according to daylight level :

- the user sets the switching level
- the photo cell measures the external light level.

Applications

Domestic and commercial premises.

Complies with EN60730

Technical data

Supply : 230V +10%-15% 50Hz
1 changeover contact 16A 250V

Selection switch:

(EE 100, EE 101, EE 110)
5 to 100 lux
50 to 2000 lux

4 position override switch allowing :

- auto : normal operation mode
- on : permanently switched-on
- off : permanently switched-off
- test : setting mode for easy adjustment

A light indicator when installing shows the status "on" of the contact.



EE100



EE702



EE002



EE003

Designation	Characteristics	Width in 17.5mm	Pack qty.	Cat. Ref.
Twilight switch with surface cell EE 003	Adjustable 5 to 100 lux, 50 to 2000 lux Fixed ON/ OFF delay: 15 to 60s Changeover 16A AC1 250V~	3	1	EE100
Twilight switch with flush cell EE 002	Adjustable 5 to 100 lux, 50 to 2000 lux Fixed ON/ OFF delay: 15 to 60s Changeover 16A AC1 250V~	3	1	EE101
Programmable twilight switch with surface cell	Daily cycle electromech. switch	5	1	EE110
Programmable twilight switch with surface cell	Weekly cycle digital program 8 presetted programs	3	1	EE170
Programmable twilight switch with surface cell	Weekly cycle digital program free setting	3	1	EE171
Compact twilight switch IP 55 Integrated cell	10 or 30 lux ON delay: 40s/ OFF delay: 120s 8A AC1	-	1	EE701
	Adjustable: 2 to 2000 lux Adjustable: 1s to 120s 16A: AC1	3	1	EE702
Flush cell	IP54 for EE100, 101, 110 & 170	-	1	EE002
Surface cell	IP54 for EE100, 101, 110 & 170	-	1	EE003

Technical specifications

	EE100	EE101	EE110	EE170	EE171	EE700
Width in ■ 17.5mm	3	3	5	3	3	-
Electrical characteristics						
voltage supply	230V +10/-15%					230V ±10%
frequency	50Hz					50/60Hz
consumption	1.5VA maximum					1VA
output	1 voltage free changeover contacts					1NO
Maximum switching capacity						
AC1	16A / 250V					10A
incandescent lamps	2000W					2300W
230V halogen lamps	1000W					
fluorescent lamps, non compensated	1000W					2300W
fluorescent lamps, compensated	200W					
fluorescent lamps compensated in series	1000W					
duo fluorescent lamps	1000W					
Functional characteristics						
lighting level : 2 ranges	5 to 100 lux and 50 to 2000 lux				2 to 1000 lux	
ON and OFF delay	15 to 60 seconds					ON 10s OFF 40s
mounting of cell	surface	flush *	surface	surface	surface	
programmable	no	no	yes	yes	yes	no
technology			electromechan.	digital		
cycle			24 hours	7 days**	7 days	
programming setting			15 min.	1 min.	1 min	
accuracy			+/- 6min/year	+/-6min/year	+/-6min/year	
operating reserve			accu	lithium battery	lithium battery	
			200h after beeing connected for 120h	total of 3 years of supply failure	total of 3 years of supply failure	
Environment						
working temperature	-30°C to +60°C (cell) -10°C to +50°C (modular device)					-25°C to +45°C
storage temperature	-20°C to +60°C					
Connection						
maximum length between cell and modular	50 meters					
capacity (modular device)	0.5 to 4 mm ²					2.5 mm ² max
capacity (cell)	0.75 to 4 mm ²		0.75 to 4 mm ²			

Note : * delivered with a 1m cable (2x0.75)
** 8 predefined programs

Cells	EE002	EE003
Type	flush mounting	surface mounting
Dimension (mm)	89 x 48 x 32	25 x 25 x 20 hole ø 25mm
Connection	cable 1m 2 x 0.75 mm ²	0.75 to 4 mm ²
Protection class	IP54	IP54
Working and storage temperature	-30°C to +60°C	-30°C to +60°C

Wiring diagram

EE100 - EE101 - EE171

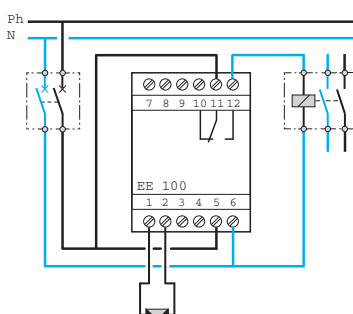

EE110

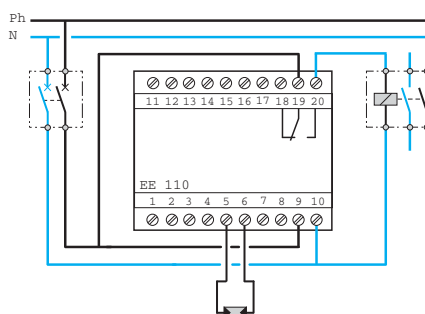

EE700

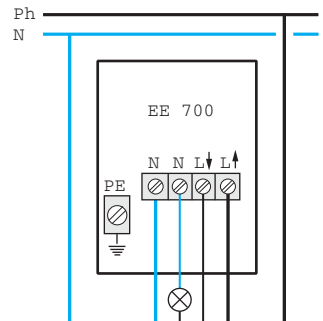

Description

Multi-function meter measures the extent of electrical values for all LV or LV/HV networks. It allows starting from the front panel to configure and display all the electric parameters and to exploit the functions of measurement, metering and energies management, harmonics analysis, remote control and control state of control devices, communication and detection of high voltages, peaks and voltage disconnections. This device is a multi-function meter for measuring electrical values for single, two and three phase low and high voltage networks.

SM102E:

- measurement in real effective values (TRMS) of:
 - current per phase and neutral in instant and maximum value,
 - phase-to-neutral and phase-to-phase voltages, In instant,
 - frequency, In instant,
 - active positive power total in instant and maximum value,

- reactive positive power total in instant and maximum value,
- apparent positive power total in instant and maximum value,
- power factor (PF) total with inductive or capacitive indication
- harmonic distortion rate (THD) up to 51 on phase-to-neutral and phase-to-phase voltages and currents (THD 3U, THD 3V, THD 3I)

Energies meters

- positive active energy meter
- positive reactive energy meter
- programmable hour run meter

SM103E:

- Same measures as for SM102E with average values,
- active and reactive power on 4 quadrants (\pm),
- harmonic distortion rate (THD) up to 51 on phase-to-neutral and phase-to-phase voltages and currents (THD 3U, THD 3V, THD 3I, THD In),

Metering:

- active and reactive power meter on 4 quadrants,
- apparent power meter,
- programmable hour run meter.

Common equipments:

- backlit LCD screen,
- direct access key for currents (instantaneous and max. values), current THD and set up wiring correction,
- direct access key for voltages, frequency and voltage THD,
- direct access key for active, reactive and apparent power (instantaneous and max. values) and power factor,
- direct access key for energies and hour meters.

Connection capacity:

- voltage: rigid or flexible conductors 2,5 mm²
- current: rigid or flexible conductors 6 mm²

Comply with IEC 61 557-12, IEC 62 053-22 class 0.5 S and IEC 62 053-23 class II

Designation	Characteristics	Cat. Ref.
Low voltage multi-function meters	measures of instantaneous and maximum values	SM102E
Low and high voltage multi-function meters and network analyser	measures of instantaneous, average and maximum values	SM103E
Pulse output module 2 pulse outputs cable for configuration (kWh, kvarh, kVah)	for meter SM102E with 1 adjustable output for meter SM103E SM201 with 2 adjustable outputs	SM200 SM201
Input / output module 2 inputs, 2 outputs cable for configuration on various measures	for meter SM103E SM202 (3 modules max. can be connected)	SM202
Analogue outputs module 2 outputs cable for configuration on various measures	for meter SM103E (2 modules max. can be connected)	SM203



SM102E



SM103E

Technical characteristics

	SM102E	SM103E
Current measurement on insulated inputs (TRMS)		
CT primary	10 000 A	10 000 A
CT secondary	5 A	1 and 5 A
Measurement range	0-11 kA	
Input consumption	0.6 VA	≤ 0.1 VA
Accuracy	0.2 %	
Sustained overload	6 A	
Intermittent overload	10 x I _n for 1 s	
Voltage measurement (TRMS)		
Direct measurement between phases	50 - 500 V	18 - 700 V
Direct measurement between phases and neutral	28 - 289 V	11 - 404 V
Frequency	50/60 Hz	
Input consumption	≤ 0,1 VA	
Accuracy	0.2 %	
Power measurement accuracy	0.5 %	
Power factor measurement accuracy	0.5 %	
Frequency measurement range	45 - 65 Hz	
Frequency measurement accuracy	0.1 %	
Active energy accuracy	class 0.5 S	
Reactive energy accuracy	class 2	
Measurement updating period	1 s	
Copper conductor connection capacity	flexible or rigid: 2,5 mm ²	
- voltage	flexible or rigid: 6 mm ²	
- current		
Auxiliary		
Power supply		
- AC voltage	110 - 400 V AC ± 10 %	
- DC voltage	120 - 350 V DC ± 20 %, 12 - 48 V DC -6 to +20 %	
Frequency	50/60 Hz	
Consumption	≤ 10 VA	

Dimensions

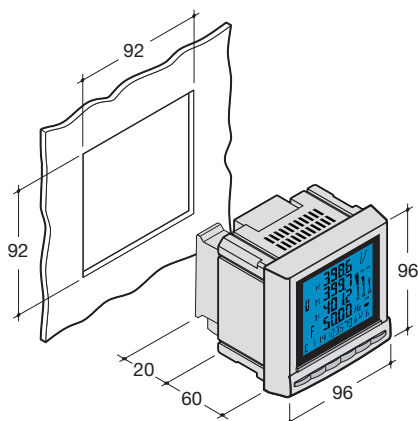

Automatic detection

Optimized control & energy consumption

The motion detector range is particularly adapted to building external lighting automation. It brings a lot of benefits, such as: comfort, safety and energy saving.

Matching with different detection and installation specifications, the detectors are available with a mounting set for wall and ceiling.



Motion detector	70
-----------------	----

360° detector	71
---------------	----

Features :

- Large range: from 200° basis to 220/360° comfort
- An IP55 reinforced waterproofing
- Detection head with overmoulded fresnel lenses and pyro detectors
- Vertical and horizontal orientation and shutters to adjust the detection area
- Local setting time and lux via potentiometers and quick set feature to ease the setting
- Installation and wiring with quick connect terminals
- Wall mounting with a wall bracket that offers numerous wiring and mounting possibilities

Technical

Power supply:

Basic detector

230 VAC + 10% (50/60 Hz)
10A AC1 relay and cutted phase
Enhanced detector
230 VAC + 10%/ -15%

Output:

16A AC1 relay potential free

	Designation	Detection angle	Colour	Pack qty.	Cat. ref.
 EE830	Basic range Lumimat S220 white/ Motion dector	200°	white	1	EE830
	Lumimat S220 anthracite/ Motion dector	200°	anthracite	1	EE831
	Lumimat S360 white/ Motion dector	360°	white	1	EE840
	Lumimat S360 anthracite/ Motion dector	360°	anthracite	1	EE841
 EE840	Enhanced range Lumimat E220 white/ Motion dector comfort	220°	white	1	EE860
	Lumimat E220 white/ Motion dector comfort	220°	anthracite	1	EE861
	Lumimat TWIN white/ Motion dector comfort	220° + 360° = Twin	white	1	EE870
	Lumimat TWIN anthracite/ Motion dector	220° + 360° = Twin	anthracite	1	EE871
 EE870 EE871					
	Accessories IR remote control		/	1	EE806
 EE806	Corner bracket for Lumimat S140/S200		white	1	EE825
			anthracite	1	EE826
 EE825	Ceiling bracket for Lumimat S140/S200		white	1	EE827
			anthracite	1	EE828
	Corner bracket for Lumimat S140/S220/TWIN		white	1	EE855
			anthracite	1	EE856

Description

Standard detectors are designed for automatic control of lighting for private/ public industry sectors and residential applications. They automatically switch on lighting if a person in motion is detected. The lights turn off after a preset duration. These detectors provide comfort and safety on the ways around a house, in the halls of passage. They also save energy by turning on the lighting only when it is necessary.

Technical data

- surface mounting
- 230 V AC, 50/60 Hz
- brightness: 5 to 1000 lux
- time delay setting: 5s to 15 min
- resistive potential free relay contact: 8A AC1 for enhanced.
- high sensitivity of detection
- remote control fro enhanced version.
- detection areas from 140° up to 360° by using mounting accessories.

Connection capacity

- 2.5mm² max rigid and flexible wires

Complies with
IEC 60 669-1 and
IEC 60 669-2-1

Designation	Characteristics	Pack qty.	Cat.Ref
-------------	-----------------	-----------	---------



EE804

**Indoor motion detectors
IP21**

360° surface mounting

1

EE804

360° flush mounting

1

EE805



EE805



EE883

**HF motion detector
(hyper frequency)
IP54**

- 1 way, 10A AC1
- detection distance from 1-8m
- Standards: EN 60669-2-1
- RF Standard ETSI EN 300 440- 1V1.3.1
- Frequency 50Hz
- Transmitter frequency: 5.8 GHz +/- 0.075 GHz
- Transmitter power: max. 1 mW
- Capture area 360°
- Back End/ Front End Protection: IP54

1

EE883

Technical characteristics

	EE820 / EE830 / EE840	EE821 / EE831 / EE841
Functional characteristics		
colours	white	anthracite
detection range	140° / 200° / 360°	
vertical head orientation	tilt 0 to 30°	
horizontal head orientation	pan ± 80°	
shutters	delivered with the products	
ceiling mounting	w/ accessory EE827 (except EE840)	w/ accessory EE828 (except EE841)
corner mounting (inner/outer corner)	w/ accessory EE825 (EE855 for EE840)	w/ accessory EE826 (EE856 for EE841)
Settings		
lux setting via potentiometer	5 to 1000 lux	
timer setting via potentiometer	pulse (1s ON, 9s OFF) or timer 5s to 15 min	
quick setting	auto/test position	
Electrical characteristics		
power supply	230V AC (+10% / -15%), 50Hz/60Hz	
output	10A AC1 , relay cutted phase	
Load type		
incandescent load	1500W	
VLV halogen lamps with conventional transformer	1500VA	
fluorescent tubes with parallel compensation C= 32µF	290W	
electronic ballast	580W	
fluocompact	10 x 20W	
Environment		
IP	55	
IK	04	
working temperature	-20°C to +55°C	
storage temperature	-20°C to +60°C	
Connection		
terminals	quickconnect with manual release	
terminals capacity	1.5 mm ² rigid wires	

Auto/OFF

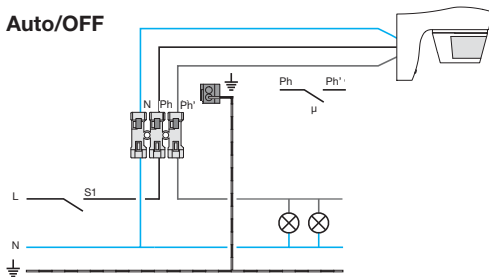

Auto/ON

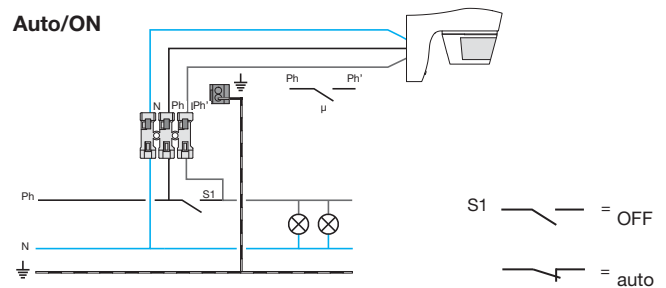

Detectors in parallel

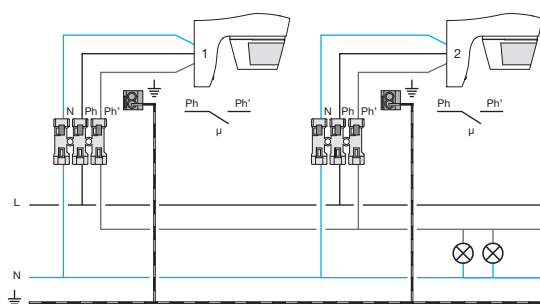

Combination with a timelag

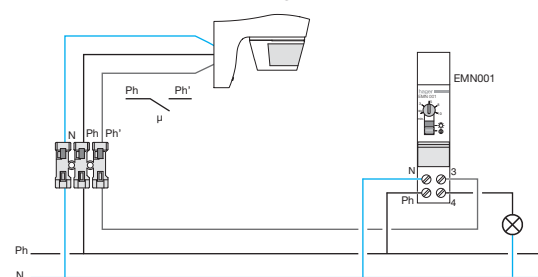

Detection zone

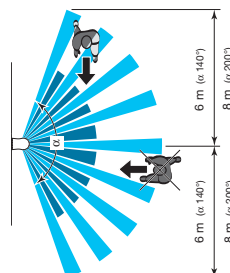
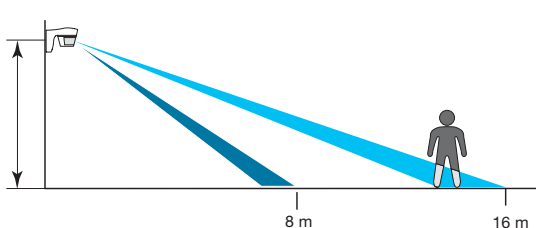

The optimal height of installation is 2.5 m.
The detection field must remain free.

EE82x: = 140°
EE83x: = 200°

Technical specifications

	EE804	EE805
mounting	wall mounted	flush mounted
voltage supply	230 V AC	
frequency	50 Hz	
brightness level	5 to 1000 lux	
lighting output operating time	5 s. to 15 mn	
breaking capacity AC1	10 A	
- incandescent	1000 W	
- halogen 230 V	1000 W	
- halogen ELV via ferro.transfo.	500 VA	
- halogen ELV via electro.transfo.	500 VA	
- non compensated fluorescent tubes	1000 W	
- compensated fluorescent tubes	2 x 58 W or 3 x 36 W or 6 x 18 W	
- electronic ballast	8 x 58 W	
- fluocompact	10 x 20 W	
terminal capacity	1 to 2,5 mm ²	
IP	IP21 / IK03	
working temperature	0°C to + 45°C	
product dimension	EE804 : Ø 105 x p.54	EE805 : Ø 85 x p.80

Detection area EE804 - EE805

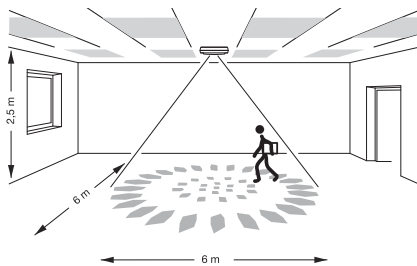

Mounting - Motion detectors 360° EE804 - EE805

ceiling mouting
They are particularly intended for use in interior traffic areas such as corridors, entrance halls...

Dimensions EE804

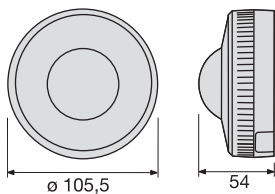

EE805

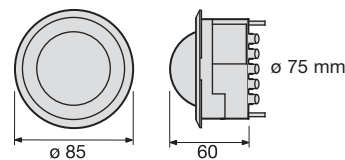

Electrical connections EE804

Operation Auto/OFF

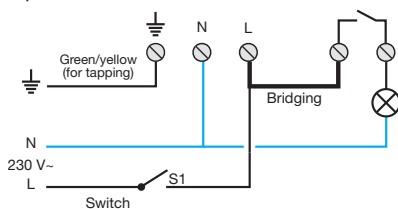

S1 Open = stop
S1 Closed = automatic mode.

Operation Auto/ON

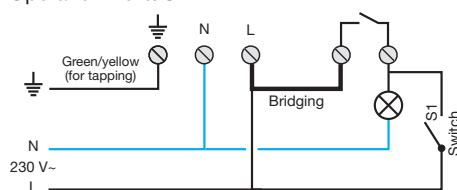

S1 Open = automatic mode
S1 Closed = permanent switch on

EE805

Operation Auto/OFF

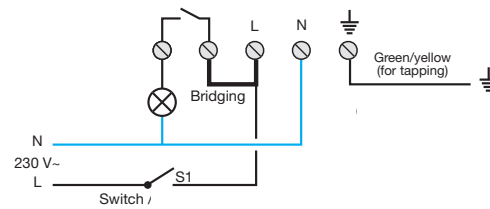

S1 Open = stop
S1 Closed = automatic mode

Operation Auto/ON

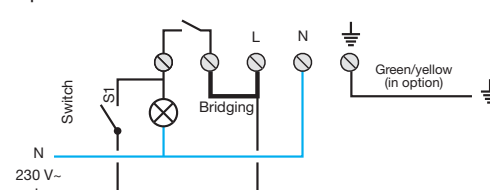

S1 open = automatic mode
S1 closed = permanent switch on.

Solutions for energy efficiency



hager



Lighting management by Hager

There is always a solution to customize the lighting to the right need and generate savings in housing and commercial premises.

www.hager.hk

