

Thanks for purchasing XINJE XD series PLC and extension module. This manual will introduce the electric features and using method of XD series extension ED module. Please read this manual carefully before using the products, make sure the wiring operation is safe.

Features of analog extension module

XD-2AD2DA-V-ED

- 2 channels analog input: voltage input mode, 0~5V or 0~10V.
- 2 channels analog output: voltage output mode, 0~5V or 0~10V.
- 12-bit high precision analog input, 10-bit high precision analog output.
- As the special function ED module of XD, XD series PLC can connect 1 XD-2AD2DA-V-ED module.

Safety precautions

Control system design attentions

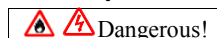

- Make sure design the safety circuit, to ensure that the control system can still work safety when the external power supply cut off or PLC broken.
- Make sure set emergency braking circuit, protection circuit, interlock circuit of forward-reverse running in PLC external circuit and upper-lower limit switch to prevent from machine damage.
- In order to make the equipment safe operation, please design external protection circuit for important output signal.
- PLC CPU will close all the output when detecting the system error; the output will lose control when the PLC circuit has problem. Please design suitable external control circuit to ensure the device working normally.
- If the PLC relay or transistor unit is broken, the output cannot be ON or OFF.
- The PLC is designed for indoor environment, the lightning protection must be installed in the power supply system to avoid PLC and other device damage.

Installation and wiring attentions



- Do not use the PLC in the following environment: dust, soot, corrosive gases, flammable gas, high temperature, condensation, vibration, impact, lightning, fire.
- Do not let the metal scrap and wire head drop into the ventilation hole of PLC, otherwise it will cause fire or error operation.
- Do not cover the ventilation hole of PLC, otherwise it will cause fire, error operation.
- The I/O wiring must be fixed enough, otherwise the bad contactor will cause fault.

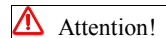

- It can use external power supply for extension module DC24V power.
- Please use shield cable for high frequency I/O wiring to avoid interference.

Run and maintenance

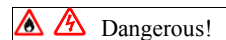

- Please connect all the cable include PLC, extension module and BD board after shutting down the power supply.
- Please operate as the manual for online operation, forced output, RUN, STOP.



- Please discard the product as industrial waste.

- Make sure cut off the power supply when installing or uninstalling the extension card.

Product information

Naming rule

XD- 2 AD 2 DA - V - ED

- Product series XD: XD series extension module
- Analog input channel: 2: 2 channels
- Analog input AD: analog input
- Analog output channel: 2: 2 channels
- Analog output DA: analog output
- I/O type V: voltage type for input and output
- Module type ED: left extension ED module

Basic parameters

XD series PLC can connect 1 extension ED module, the type is not limited.

Table 1: analog extension module XD-2AD2DA-V-ED general specifications

Item	Specifications
Using environment	No corrosive gas
Environment temperature	0°C~60°C
Storage temperature	-20~70°C
Environment humidity	5~95%RH
Storage humidity	5~95%RH
Installation	Fix with M3 screw or install on the rail DIN46277(width 35mm)
Dimension	100.0mm×18.0mm×90.0mm

Table 2: analog extension module XD-2AD2DA-V-ED I/O precision

Item	Analog current input (V)	Analog current output (V)
Analog input range	0~5, 0~10V	—
Max input range	0~40mA	—
Analog output range	—	0~5, 0~10V External load resistor is 2KΩ~1MΩ
Digital input range	—	10-bit binary number (0~1023)
Digital output range	12-bit binary number (0~4095)	-
Resolution	1/4095(12Bit)	1/1023(10Bit)
integrated precision	1%	
Transformation speed	2ms/1 channel	2ms/1 channel
Power supply for analog	DC24V±10%, 150mA	

Table 3: analog extension module XD-2AD2DA-V-ED AD transformation diagram

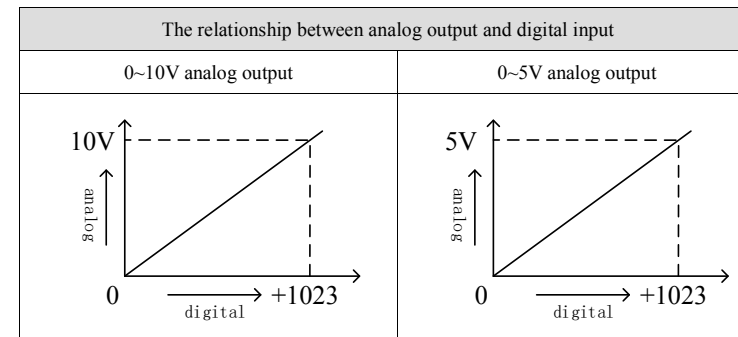
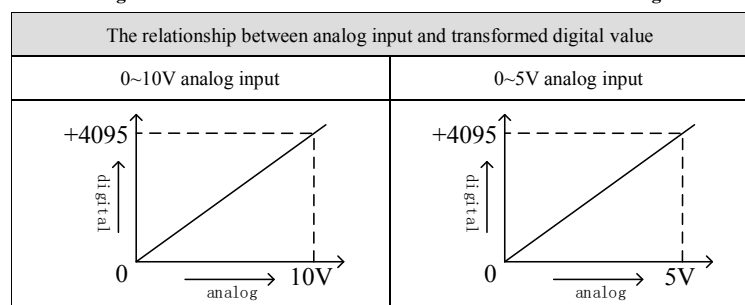

Note: when the input data is over K1023, DA transformed analog output will keep the max voltage.

Product appearance

Here listed I/O terminal configurations of XD series extension module XD-2AD2DA-V-ED.

Product structure

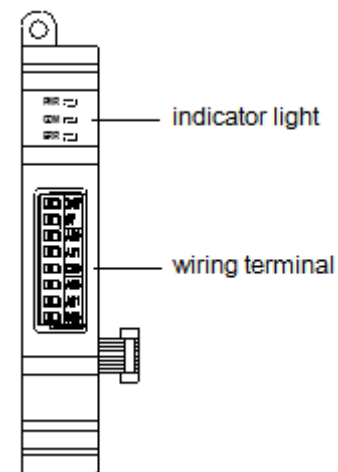

Each part name:

Name	Function
Indicator light	PWR The LED lights when the ED module has power supply
	COM The LED lights when the ED module communication port works well
	ERR The LED lights when the ED module has error
Wiring terminal	24V ED module external power supply 24V +
	0V ED module external power supply 24V -
	VI0 Channel 1 analog input
	VI1 Channel 2 analog input
	CI0 VI0, VI1 ground
	VO0 Channel 1 analog output
VO1 Channel 2 analog output	
CO0 VO0, VO1 ground	

Product dimension and installation

Installation

Do not install the module in below environment:

- Direct sunlight
- Environment temperature out of range 0-50°C
- Environment humidity out of range 35%-85% RH
- Condensation as severe changes in temperature
- Corrosive gas and flammable gas
- Dust, iron filing, salt, fume
- Vibration and impact
- Spray oil, water and medicine
- Strong magnetic field and strong electric field

XD series extension ED module can be installed in com3 port of XD series PLC.

Note: please cut off the power before operation!

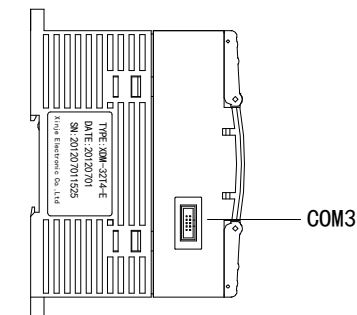

Product dimension (Unit: mm)

XD series extension ED module dimension is shown as below:

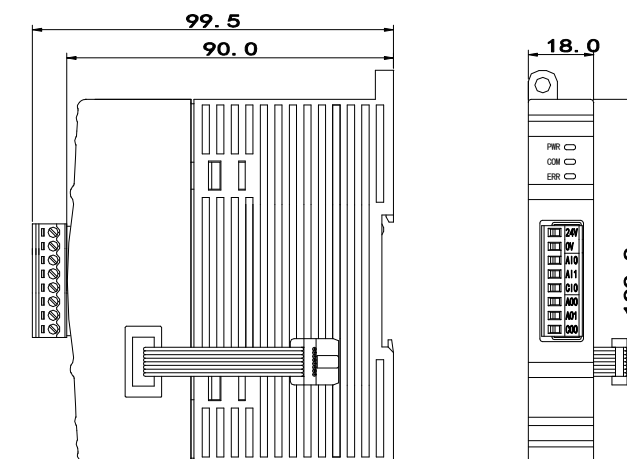

Electric design reference

I/O address

XD series extension ED module will not occupy I/O unit, the transformed value is stored in PLC register. The following is the PLC register corresponding to each channel.

Channel	AD signal
0CH	ID30000
1CH	ID30001
Channel	DA signal
0CH	QD30000
1CH	QD30001

Working mode setting

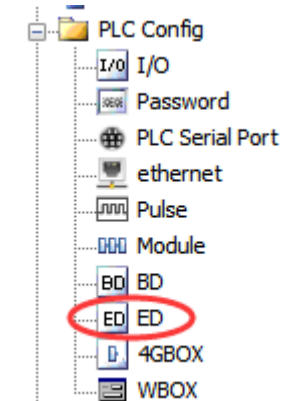

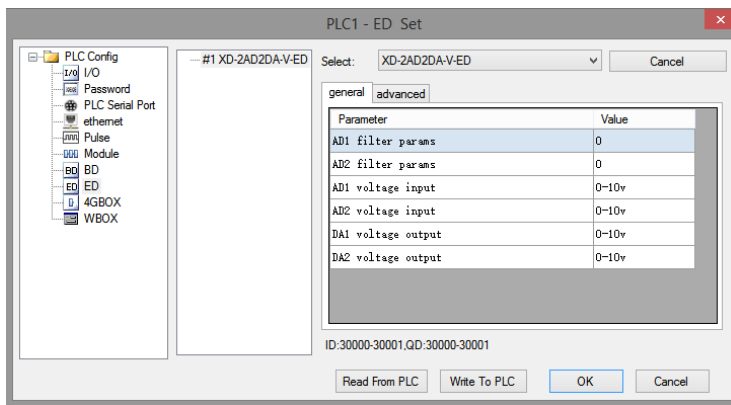

Steps:

1. open the XDPpro software, find the left project bar, click PLC config/ED.
2. choose the correct module type.
3. set the module parameters such as voltage input range.
4. click write to PLC, then re-power on the PLC to make the setting effective.

Note: first-order low-pass filtering weighted this sampled value with last filter output value, and got the effective filtering value. The filter coefficient is set by user, the range is 0-254, 0 means no filter.

External connection

Please pay attention to below items when wiring:

- ① please use shield cable to avoid interference, and single point connect to ground for the shield layer.
- ② when XD-2AD2DA-V-ED connects external +24V power supply, please choose the power supply from PLC to avoid interference.

Voltage single-ended input

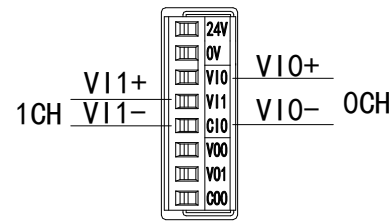

Voltage single-ended output

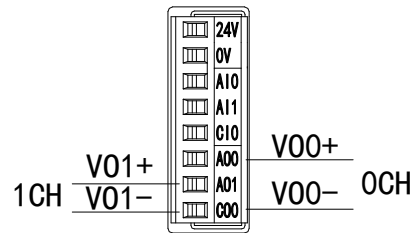

Programming example

Example: it needs to collect one channel pressure sensor signal (pressure sensor performance parameter: pressure range 0Mp~10Mp, output signal range 0-10V), and it needs to output a 0~5V signal to VFD.

Analysis: as the pressure sensor testing range is 0Mp~10Mp, and related analog output is 0-10V, the ED module AD transformation range is 0~4095. So 0Mp~10Mp is related to digital range 0~4095. $10\text{Mp}/4096=0.0024414$ is the pressure value related to digital value 1. So the real-time pressure=ID register value * 0.002441406. For example, ID register value is 1024, so the pressure is 2.5Mp.

ED extension module QD register value 0~1023 is related to current output range 0~5V, $5\text{V}/1024=0.0048828$ is the output current related to digital value 1. For example, it needs to output voltage 2.5V, the digital value is $2.5/0.0048828=512$ which will be sent to QD register.

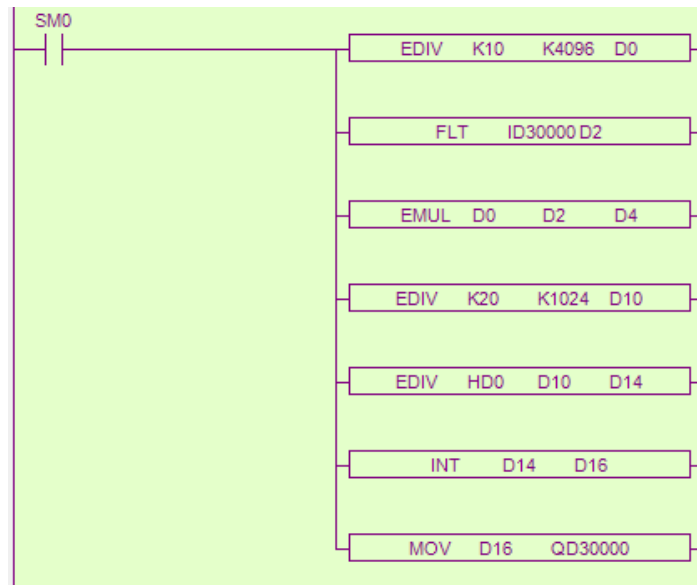

Note: please use floating number for calculation, otherwise the calculation precision will be error!

Explanation:

SM0 is normally ON coil, it will be ON when PLC is running.

PLC will calculate the pressure value P related to digital value 1, then transform the ID30000 value to floating number. So the real-time pressure=ID30000*P.

PLC will calculate the voltage value C related to digital value 1, so the setting digital value(floating number)=target voltage value/C. Then transform the result (floating number) to integer then send to QD30000.

In this example, we use AD channel 1 and DA channel 1, please set ON related channel enable bit Y30000, Y30002.